



PRINT 
ACOUSTICS
acoustic absorbing panels



CONTENT

Content	2
Principle of Print Acoustics® panels	3
Applications and solutions	6
Overview collection	7
Type S (wall)	8
Type F (wall)	10
Type G (wall)	12
Type Db (wall)	14
Type Db (door 20 mm)	16
Type Ds (wall)	18
Type Dr (wall)	20
Type Dr (door 20 mm)	22
Type Z (wall & ceiling)	24
Type M (wall)	26
Composition of Type M	28
Type M (door 20 mm)	30
Type T (wall)	32
Type I (wall 10 mm)	34
Type I (door 18 mm)	36
Type C (wall)	38
Type B (wall)	40
Type W (wall)	42
Digitally printed panels	44
Furniture doors made-to-measure	45
Technical datasheet of PRIMAWOOL®	47
Description of surface	48
Storage of finished panels	49
Installation of type S, F, G, D, T, W	50
Installation of type I	51
Installation of type M, C, B	52
Finishing possibilities Print Acoustics® panels	53
Advised reverberation times	58
Benefits	59

PRINCIPLE OF PRINT ACOUSTICS® PANELS

Our collection of acoustic absorbing panels is developed to **absorb** and **reduce** all kinds of disturbing noises in a room, leading to an **increased acoustic comfort**, even in rooms with large audiences and a lot of ambient noise. As the reflection of sound waves is minimized, the reverberation time and level are reduced. The sound waves are converted into mechanical energy (vibration or heat) in the panel or the wool.

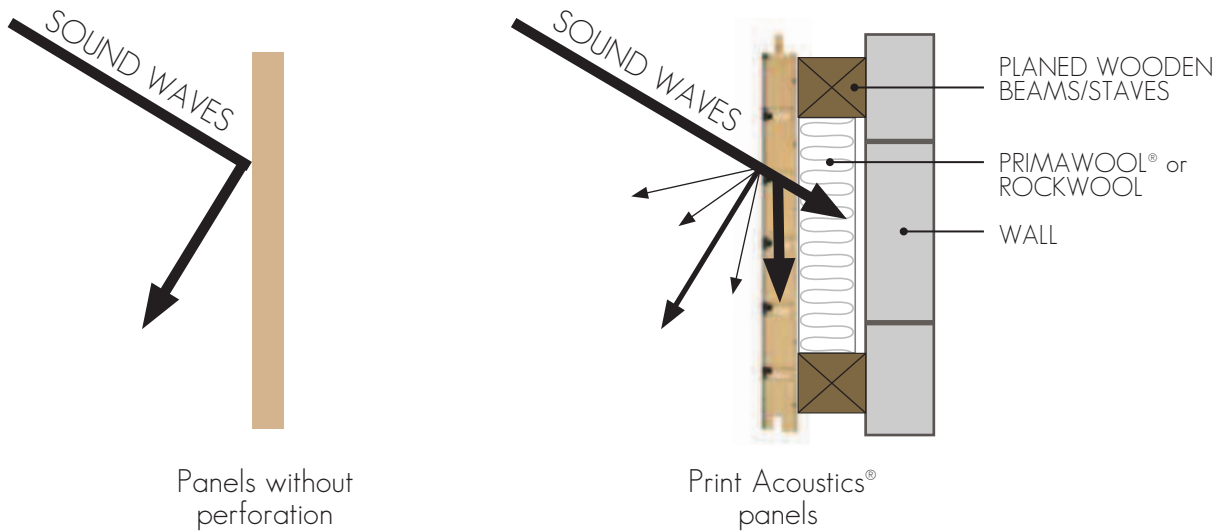

The principle of our acoustic panels

Our collection is developed in-house and thoroughly tested in a reverberation room of an independent acoustic laboratory. Detailed test results can be found in official European reports, which are available on request. The end results are displayed in charts in this brochure. The continuous investments in **product development** and the focus on even the smallest details have allowed us to optimize our product range.



Test setup of Print Acoustics® panels in a reverberation room

Various **absorption methods** can be used to limit the reverberation in rooms. Our acoustic absorbing panels use the **Helmholtz resonator principle** (= perforated panels), which is ideal for the correction of **low and medium frequency noises** (= human voice).

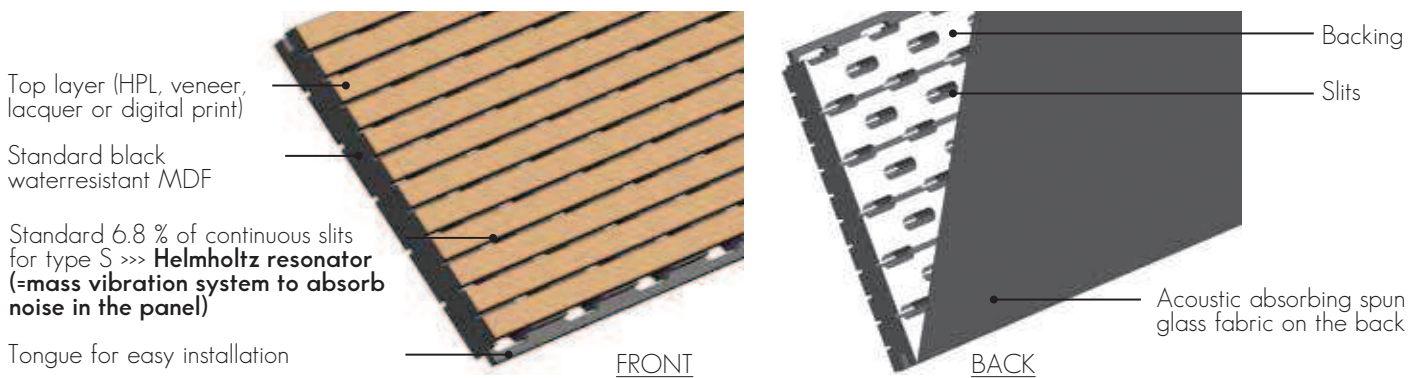
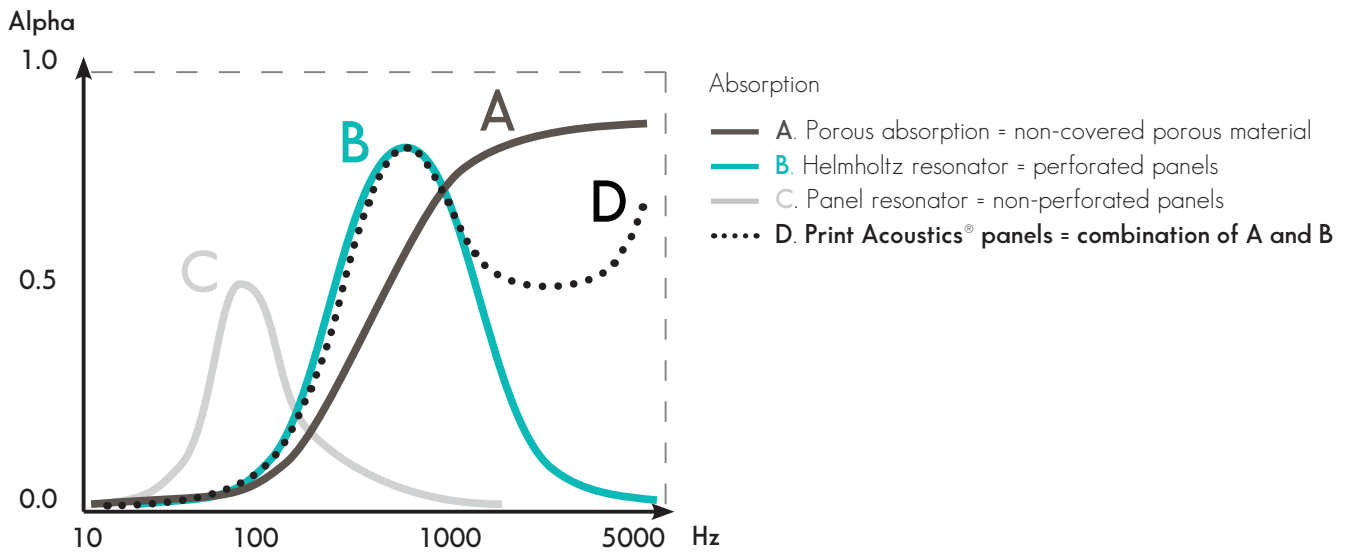

Helmholtz resonator / Setup of panel type S with tongue and groove

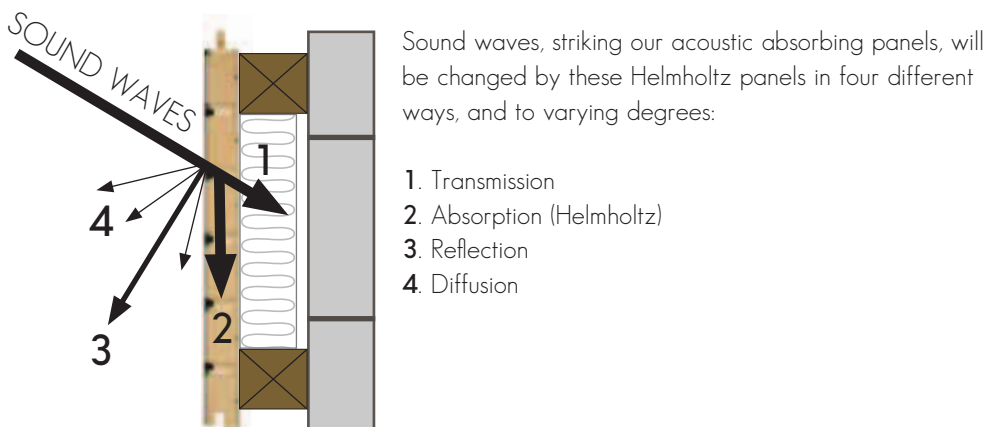

Reduction of the reflected sound energy using the "Helmholtz"-technology

Should you be interested in further information concerning the requested reverberation time in a specific room, we can give you a **target value** (see page 58). Specialised acoustic engineers can calculate the number of m² you need to use to optimize the room acoustically. As a service, we can calculate a theoretical typical value in certain applications (small rectangular volumes), giving an idea of the acoustic level in a certain design. This service is non-binding, without any commitment.

Print Acoustics® // Principe de Calcul

Client / project		Project X	
Dimensions Room			
Length (m)	11,30	Surfaces or Room:	Material
Width (m)	4,75	Walls	96,3 m ² painted brick
Height (m)	3,00	Ceiling	53,7 m ² gypsum board
Volume (m ³)	161,03	Floor	53,7 m ² ceramic tile

RT60 as is / m RT60 GOAL

Octave b. frequencies (Hz)	125	250	500	1000	2000	4000	Average 125-4000Hz
RT60 as is in s	1,7	2,8	4,9	6,8	5,7	3,6	3,28
RT60 GOAL in s	0,65	0,65	0,65	0,65	0,65	0,65	0,65

Print Acoustics® products	Needed (m ²)
Type S - PrimaWood 20mm	m ²
Type S - RockIt 50mm	m ²
Type J - PrimaWood 20mm	m ²
Type F - RockIt 50mm	m ²
Type G - PrimaWood 20mm	m ²
Type G - RockIt 50mm	m ²
Type D1b/Dr - PrimaWood 20mm	m ²
Type D1b/Dr - RockIt 50mm	46,0 m ²
Type D1b/Dr - 500mm cabinet door	m ²
Type D3 - PrimaWood 20mm	m ²
Type D3 - RockIt 50mm	m ²
Type Z - PrimaWood 20mm	m ²
Type Z - RockIt 50mm	m ²
Type M - PrimaWood 20mm	m ²
Type M - RockIt 50mm	m ²
Type M - 500mm cabinet door	m ²
Type T - PrimaWood 20mm	m ²
Type T - RockIt 50mm	m ²
Type I - PrimaWood 20mm	m ²
Type I - RockIt 50mm	m ²
Type L - 500mm cabinet door	m ²
Type L - PrimaWood 20mm	m ²
Type L - RockIt 50mm	m ²

RESULTS RT60 AFTER

Prediction of RT60 after - when soundabsorbing products are mounted in room

Octave bands frequencies in Hz	125	250	500	1000	2000	4000	Average 125-4000Hz
RT60 After in s	0,7	0,6	0,5	0,7	0,8	0,6	0,6

Single values indication

RT60 at 2000 Hz (ref. for Steps)	in s	0,8
Nominal RT60 (average of 500 and 1000 Hz)	in s	0,6
Average RT60 (average from 125 up to 4000 Hz)	in s	0,6
Max. RT60 (from 125 up to 4000 Hz)	in s	0,8

Project X
Graphic presentation

PRINT ACOUSTICS
acoustic absorbing panels

REMARKS:
METHOD OF CALCULATION: Formula of Sabine RT60 = 0,161 V / A Volume of the room A: open absorption surface
[www.print-acoustics.com/technical-calculation-including-video](#)

An example of how the reverberation times are calculated

Example of **in-situ measurement**

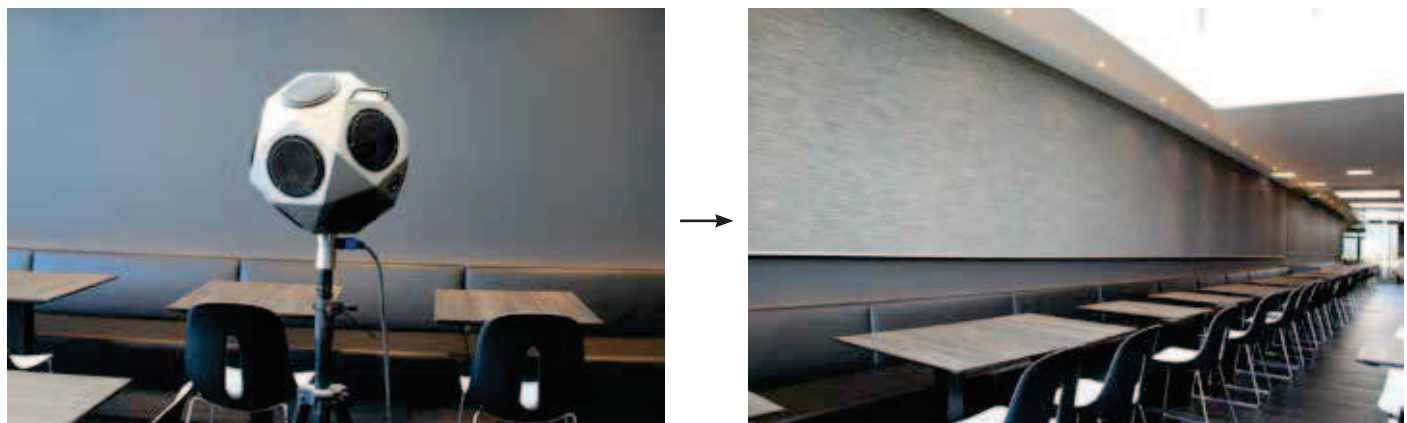

In-situ measurement before mounting acoustic absorbing panels type I in a restaurant.

APPLICATIONS AND SOLUTIONS

Our panels offer **acoustic solutions** for: walls of closets, interior wall cladding, fix or movable partitions, sliding doors, interior doors, projects, such as hospitals, retirement homes, schools, sports facilities, industry, restaurants, museums, offices, malls and (retail) stores, ...).



Sports facilities



Meeting centres



Restaurants

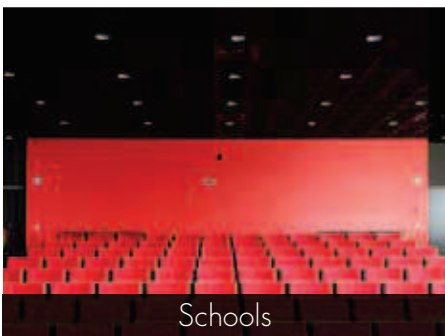

Schools



Meeting rooms



Healthcare



Cafeterias



Reception rooms & halls

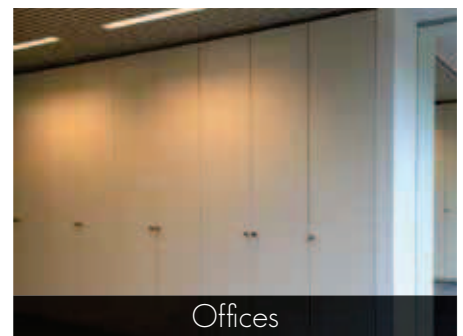

Offices



Congress rooms & auditoriums

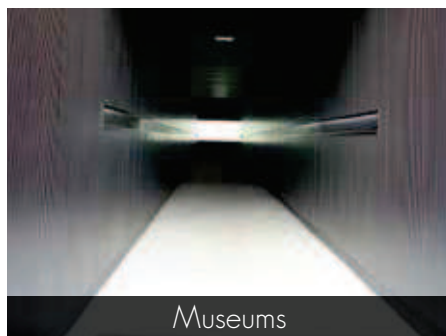

Museums



Partitions & sliding doors

OVERVIEW COLLECTION

TYPE	NAME	PERFO continuous (%)	BLADE width (mm)	GROOVE width (mm)	FORMAT & FINISHING both sides (mm)	V half groove long sides T&G tongue- groove	AlphaW	AlphaW	AlphaW	AlphaW	
							70 mm	20 mm	500 mm	500 mm	
											→ wooden laths
											→ filling
											→ brand
											→ manufacturer
											→ application
S	Slit	6.8	13.2	2.8	3030 x 1280 x 18 3030 x 192 x 18	V T&G	0.60 0.60 0.75° 0.75**	0.65 0.65 0.70° 0.67**	- - -	- - -	8
F	Fine	16	5.2	2.8	3030 x 1280 x 18 3030 x 192 x 18	V T&G	0.80 0.80° 0.79**	0.70 0.75° 0.74**	- -	- -	10
G	Hole	6.8	13.2	2.8	3030 x 1280 x 18 3030 x 192 x 18	V T&G	0.70 0.70 0.75° 0.78**	0.65 0.65 0.70° 0.69**	- -	- -	12
Db	Transverse core Wide blade	8.75	13.2	2.8	3030 x 1280 x 20 3030 x 192 x 20	V T&G	0.65 0.75° 0.77**	0.65 0.70° 0.69**	0.35 0.35° 0.34**	0.55 0.50° 0.51**	14 16
Ds	Transverse core Small blade	17.5	5.2	2.8	3030 x 1280 x 20	V	0.70 0.75° 0.77**	0.75 0.75° 0.75**	- -	- -	18
Dr	Transverse core Random blade	8.75	Random	2.8	3030 x 1280 x 20	V	0.65 0.75° 0.77**	0.65 0.70° 0.69**	0.35 0.35° 0.34**	0.55 0.50° 0.51**	20 22
Z	Z-core	7.5	23.5	8.5	3030 x 1280 x 18	V	0.60 0.75° 0.75**	0.70 0.75° 0.72**	- -	- -	24
M	Micro- perfo	4.7	n.a.	n.a.	3020 x 1270 x 20	-	0.85 0.85° 0.86**	0.70 0.75° 0.77**	0.55 0.50° 0.51**	0.70 0.65° 0.66**	26 30
T	Tile- design	6.8	29.8	2.2	3008 x 1280 x 18 576 x 576 x 18	V/V V/V	0.65 0.65 0.75° 0.75**	0.70 0.70 0.70° 0.71**	- -	- -	32
I	Invisible Wall 10 mm	n.a.	n.a.	n.a.	3030 x 640 x 10	-	0.90 0.85° 0.87**	0.60 0.70° 0.68**	- -	- -	34
I	Invisible Door 18 mm	n.a.	n.a.	n.a.	custom	-	- -	- -	0.40 0.40° 0.39**	0.65 0.60° 0.61**	36
C	Cone Drilled	7.7	n.a.	n.a.	3040 x 1280 x 18	-	0.30 0.60° 0.60**	0.50 0.60° 0.61**	- -	- -	38
B	Drilled	19.6	n.a.	n.a.	3040 x 1280 x 18	-	0.65 0.75° 0.74**	0.65 0.70° 0.68**	- -	- -	40
W	Wide	4.8	29.2	2.8	3030 x 1280 x 18 3030 x 192 x 18	V T&G	0.40 0.60° 0.62**	0.50 0.60° 0.61**	- -	- -	42

Meer info pagina

↑
Standard measurements for 0.9 mm HPL top layer or RAL coated panels. For panels with top layer in veneer the maximum width is 1200 mm.

↑
For closets, the fabrics side of the PRIMAWOOL can be stuck on the back of the interior of the closet for improved absorption.
(Test with empty closet.)

* NRC (Noise Reduction Coefficient): arithmetic average of the measured sound absorption coefficient alpha^s at frequency levels 250, 500, 1000 and 2000 Hz.

** SAA (Sound Absorption Average): arithmetic average of the measured sound absorption coefficient alpha^s at frequency levels 200 up to 2500 Hz.

TYPE S (wall)



2.8 mm 13.2 mm

THICKNESS +/-18 mm

WEIGHT 12 kg/m²

MATERIAL COMPOSITION

- A Core of 16 mm in MDF
- High-quality two-sided HPL finish (EN 438) of Abet Laminati
- Acoustic absorbing non woven glass fibre tissue

STD. MEASUREMENTS

- 3030 x 192 mm (tongue/groove)
- 3030 x 1200 mm (veneer)
- 3030 x 1280 mm (HPL)

Made-to-measure on request.

PERFORATION

Standard 6.8 % continuous slits
Blade/groove: 13.2/2.8 mm

TOP LAYER

Print HPL 0.9 mm.
On request: lacquer, veneer or digital print.

CORE

Black moisture repellent MDF.
On request: standard MDF, red or black fire retardant MDF (B-s1-d0).

TEST SETUP
IN LAB:
WALLS

TOTAL THICKNESS
88 mm

f(Hz)	T1 (s)	T2 (s)	α_s
50			
63			
80			
100	7,36	5,14	0,13
125	8,98	3,73	0,41
160	9,81	3,21	0,55
200	10,03	2,54	0,78
250	8,57	2,17	0,91
315	7,84	1,85	1,09
400	7,01	1,85	1,05
500	6,74	1,99	0,94
630	6,76	2,16	0,83
800	6,71	2,39	0,71
1000	7,01	2,68	0,61
1250	6,89	2,80	0,56
1600	6,09	2,76	0,52
2000	5,47	2,66	0,51
2500	4,76	2,42	0,54
3150	3,93	2,12	0,57
4000	3,15	1,81	0,62
5000	2,47	1,54	0,65

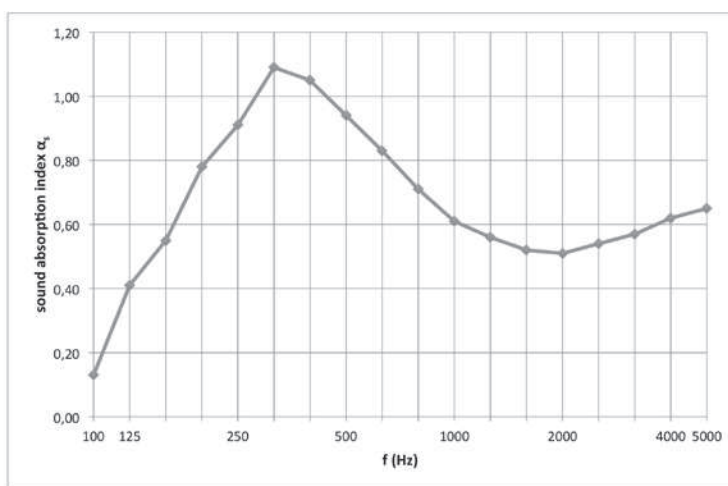

f(Hz)	α_p
125	0,35
250	0,95
500	0,95
1000	0,65
2000	0,50
4000	0,60

$\alpha_w = 0,60$ (LM)
acoustical absorption class : C

Type S 6.8 % 13.2/2.8 mm

To be mounted on a wooden frame with a thickness of 70 mm, filled with 50 mm of Rockfit 431 adapt 40 kg/m³.

TEST SETUP
IN LAB:
WALLS

TOTAL THICKNESS
38 mm

f(Hz)	T1 (s)	T2 (s)	α_s
50			
63			
80			
100	11,86	9,43	0,08
125	10,87	7,81	0,13
160	9,83	6,93	0,16
200	10,35	6,11	0,25
250	9,94	5,02	0,37
315	9,36	4,35	0,46
400	9,27	3,81	0,58
500	9,64	3,30	0,74
630	10,57	2,96	0,90
800	10,39	2,76	0,99
1000	10,08	2,77	0,98
1250	9,15	2,97	0,85
1600	7,94	3,12	0,74
2000	6,68	3,21	0,63
2500	5,35	3,05	0,56
3150	4,16	2,68	0,56
4000	3,26	2,24	0,62
5000	2,42	1,72	0,78

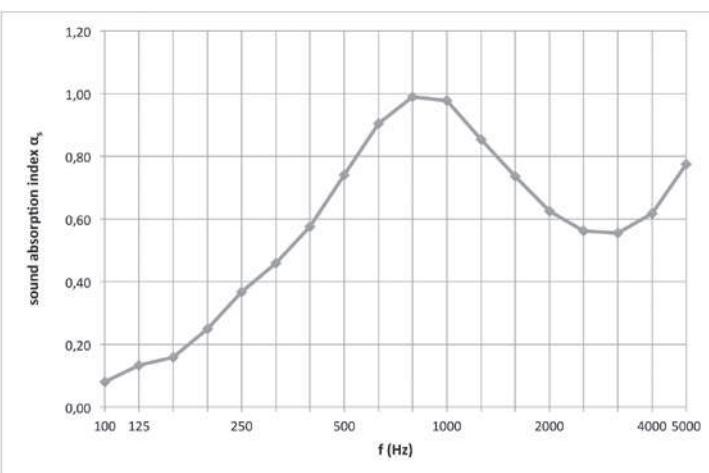

f(Hz)	α_p
125	0,10
250	0,35
500	0,75
1000	0,95
2000	0,65
4000	0,65

$\alpha_w = 0,65$ (M)
acoustical absorption class : C

Type S 6.8 % 13.2/2.8 mm

To be mounted on a wooden frame with a thickness of 20 mm, filled with 20 mm of PRIMAWOOL 22.5 kg/m³.

TYPE S (wall)



INSTALLATION see page 50

A core of 16 mm in black MDF with acoustic absorbing non woven glass fibre tissue on the back.



Top layer and backing in Print HPL 0.9 mm.
(On request: lacquer, veneer or digital print.)

Type S 6.8 % 13.2/2.8 mm

% perfo	total thickness	α_w	NRC* <small>see page 7</small>	SAA** <small>see page 7</small>
6.8%	88 mm	0.60	0.75	0.75
	38 mm	0.65	0.70	0.67

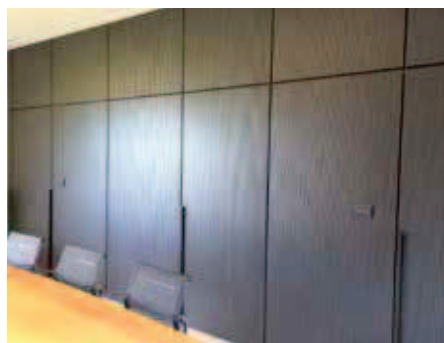

TYPE F (wall)



THICKNESS +/-18 mm

WEIGHT 11 kg/m²

MATERIAL COMPOSITION

- Core of 16 mm in MDF
- High-quality two-sided HPL finish (EN 438) of Abet Laminati
- Acoustic absorbing non woven glass fibre tissue

STD. MEASUREMENTS

- 3030 x 192 mm (tongue/groove)
- 3030 x 1200 mm (veneer)
- 3030 x 1280 mm (HPL)

Made-to-measure on request.

PERFORATION

Standard 16 % continuous slits
Blade/groove: 5.2/2.8 mm

TOP LAYER

Print HPL 0.9 mm.
On request: lacquer, veneer or digital print.

CORE

Black moisture repellent MDF.
On request: standard MDF, red or black fire retardant MDF (B-s1-d0).

TEST SETUP IN LAB: WALLS

TOTAL THICKNESS
88 mm

f(Hz)	T1 (s)	T2 (s)	α_s
50			
63			
80			
100	12,46	8,10	0,16
125	12,44	5,99	0,32
160	9,04	4,95	0,34
200	8,77	4,19	0,46
250	8,73	3,47	0,65
315	8,74	2,91	0,85
400	8,78	2,72	0,94
500	9,02	2,66	0,99
630	9,71	2,83	0,93
800	9,55	2,95	0,87
1000	9,17	3,09	0,80
1250	8,24	3,18	0,72
1600	7,14	2,97	0,74
2000	6,03	2,77	0,74
2500	4,85	2,53	0,73
3150	3,76	2,26	0,71
4000	2,93	1,96	0,71
5000	2,18	1,58	0,79

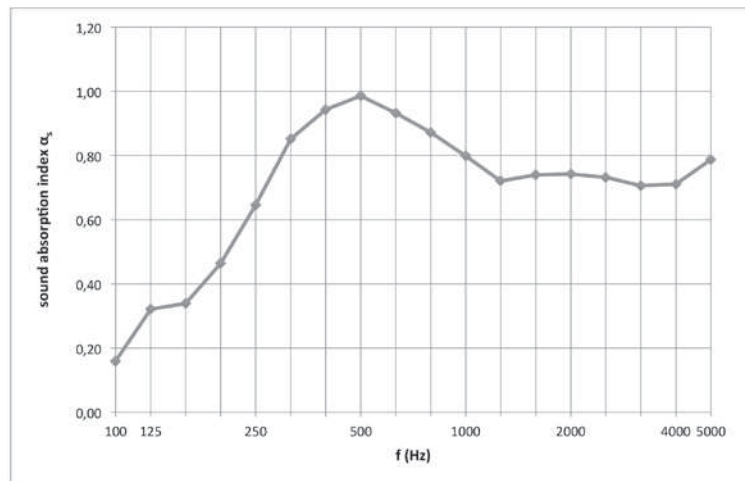

f(Hz)	α_p
125	0,25
250	0,65
500	0,95
1000	0,80
2000	0,75
4000	0,75

$\alpha_w = 0,80$ ()
acoustical absorption class : B

Type F 16 % 5.2/2.8 mm

To be mounted on a wooden frame with a thickness of 70 mm, filled with 50 mm of Rockfit 431 adapt 40 kg/m³.

TEST SETUP IN LAB: WALLS

TOTAL THICKNESS
38 mm

f(Hz)	T1 (s)	T2 (s)	α_s
50			
63			
80			
100	12,23	9,33	0,09
125	10,79	7,72	0,14
160	9,82	6,15	0,23
200	9,09	5,54	0,26
250	9,36	4,61	0,41
315	9,30	4,09	0,51
400	9,26	3,77	0,59
500	9,40	3,30	0,74
630	10,04	3,22	0,79
800	9,95	2,90	0,92
1000	9,73	2,66	1,03
1250	8,92	2,61	1,02
1600	7,72	2,63	0,94
2000	6,69	2,56	0,90
2500	5,44	2,52	0,80
3150	4,32	2,25	0,79
4000	3,40	1,92	0,84
5000	2,54	1,51	0,99

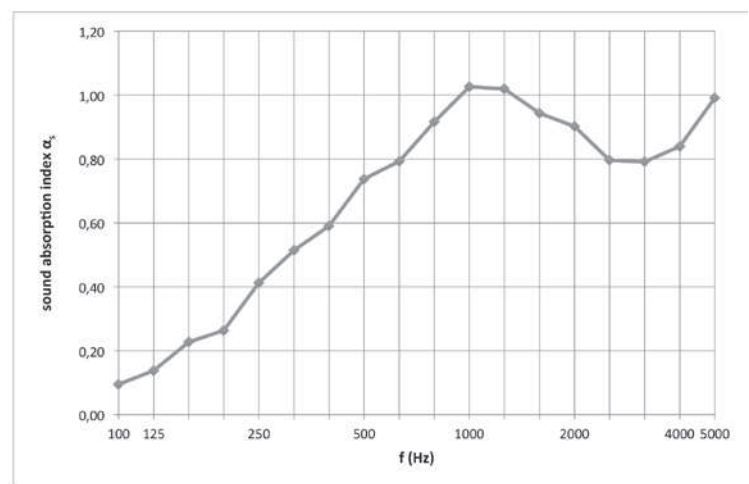

f(Hz)	α_p
125	0,15
250	0,40
500	0,70
1000	1,00
2000	0,90
4000	0,85

$\alpha_w = 0,70$ (MH)
acoustical absorption class : C

Type F 16 % 5.2/2.8 mm

To be mounted on a wooden frame with a thickness of 20 mm, filled with 20 mm of PRIMAWOOL 22.5 kg/m³.

TYPE F (wall)



INSTALLATION see page 50

A core of 16 mm in black MDF with acoustic absorbing non woven glass fibre tissue on the back.



Top layer and backing in Print HPL 0.9 mm.
(On request: lacquer, veneer or digital print.)

Type F 16 % 5.2/2.8 mm

% perfo	total thickness	α_w	NRC* <small>see page 7</small>	SAA** <small>see page 7</small>
16 %	88 mm	0.80	0.80	0.79
	38 mm	0.70	0.75	0.74

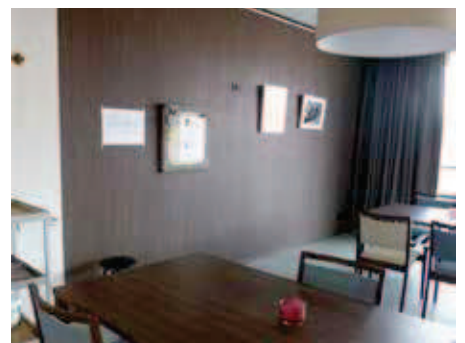

TYPE G (wall)



2.8 mm 13.2 mm

THICKNESS +-18 mm

WEIGHT 12 kg/m²

MATERIAL COMPOSITION

- Core of 16 mm in MDF
- High-quality two-sided HPL finish (EN 438) of Abet Laminati
- Acoustic absorbing non woven glass fibre tissue

STD. MEASUREMENTS

- 3030 x192 mm (tongue/groove)
- 3030 x1200 mm (veneer)
- 3030 x1280 mm (HPL)

Made-to-measure on request.

PERFORATION

Standard 6.8 % continuous slits
Blade/groove: 13.2/2.8 mm

TOP LAYER

Print HPL 0.9 mm.
On request: lacquer, veneer or digital print.

CORE

Black moisture repellent MDF.
On request: standard MDF, red or black fire retardant MDF (B-s1-d0).

TEST SETUP
IN LAB:
WALLS

TOTAL THICKNESS
88 mm

f(Hz)	T1 (s)	T2 (s)	α_s
50			
63			
80			
100	7,36	5,43	0,13
125	8,98	3,98	0,37
160	9,81	3,36	0,52
200	10,03	2,65	0,73
250	8,57	2,27	0,86
315	7,84	1,87	1,08
400	7,01	1,86	1,05
500	6,74	1,99	0,94
630	6,76	2,08	0,88
800	6,71	2,24	0,79
1000	7,01	2,50	0,68
1250	6,89	2,65	0,61
1600	6,09	2,59	0,59
2000	5,47	2,47	0,59
2500	4,76	2,29	0,60
3150	3,93	2,02	0,64
4000	3,15	1,74	0,68
5000	2,47	1,46	0,74

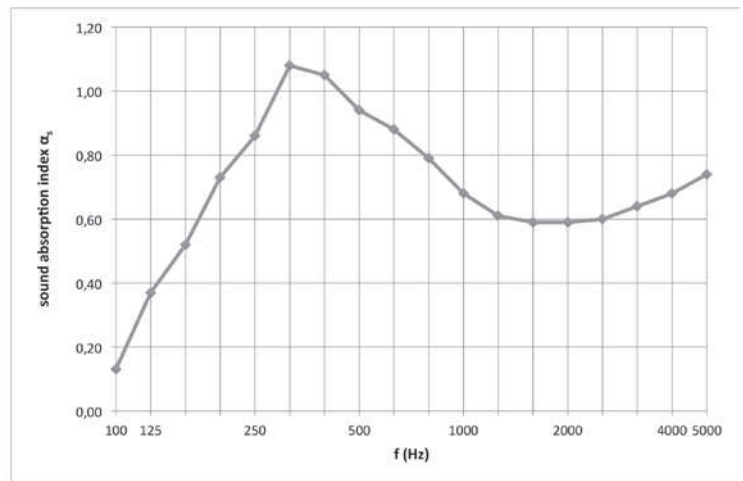

f(Hz)	α_p
125	0,35
250	0,90
500	0,95
1000	0,70
2000	0,60
4000	0,70

$\alpha_w = 0,70$ (LM)
acoustical absorption class : C

Type G 6.8 % 13.2/2.8 mm

To be mounted on a wooden frame with a thickness of 70 mm, filled with 50 mm of Rockfit 431 adapt 40 kg/m³.

TEST SETUP
IN LAB:
WALLS

TOTAL THICKNESS
38 mm

f(Hz)	T1 (s)	T2 (s)	α_s
50			
63			
80			
100	12,23	9,44	0,09
125	10,79	7,21	0,17
160	9,82	6,27	0,22
200	9,09	5,60	0,26
250	9,36	4,96	0,36
315	9,30	3,92	0,56
400	9,26	3,34	0,72
500	9,40	3,15	0,80
630	10,04	2,90	0,92
800	9,95	2,75	0,99
1000	9,73	2,72	1,00
1250	8,92	2,89	0,88
1600	7,72	3,11	0,72
2000	6,69	3,17	0,61
2500	5,44	3,09	0,51
3150	4,32	2,71	0,49
4000	3,40	2,27	0,51
5000	2,54	1,74	0,61

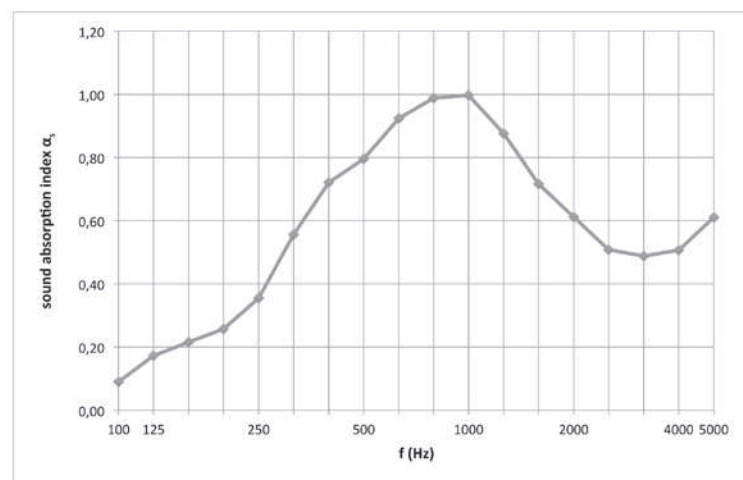

f(Hz)	α_p
125	0,15
250	0,40
500	0,80
1000	0,95
2000	0,60
4000	0,55

$\alpha_w = 0,65$ (M)
acoustical absorption class : C

Type G 6.8 % 13.2/2.8 mm

To be mounted on a wooden frame with a thickness of 20 mm, filled with 20 mm of PRIMAWOOL 22.5 kg/m³.

TYPE G (wall)



INSTALLATION see page 50

A core of 16 mm in black MDF with acoustic absorbing non woven glass fibre tissue on the back.



Top layer and backing in Print HPL 0.9 mm.
(On request: lacquer, veneer or digital print.)

Type G 6.8 % 13.2/2.8 mm

% perfo	total thickness	α_w	NRC* <small>see page 7</small>	SAA** <small>see page 7</small>
6.8 %	88 mm	0.70	0.75	0.78
	38 mm	0.65	0.70	0.69

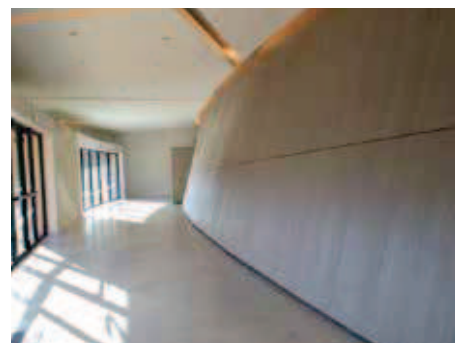
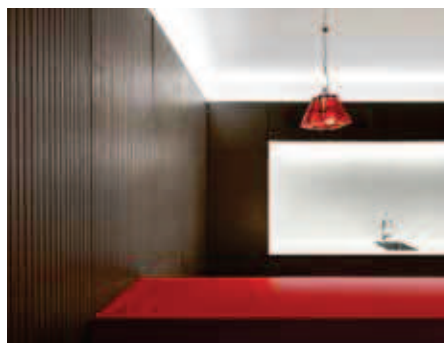

TYPE Db (wall)



2.8 mm 13.2 mm

THICKNESS +/-20 mm

WEIGHT 10,5 kg/m²

MATERIAL COMPOSITION

- Core of 2 x 9 mm in MDF
- High-quality two-sided HPL finish (EN 438) of Abet Laminati
- Acoustic absorbing non woven glass fibre tissue (in the centre of the panel)

STD. MEASUREMENTS

- 3030 x192 mm (tongue/groove)
- 3030 x1200 mm (veneer)
- 3030 x1280 mm (HPL)

Made-to-measure on request.

PERFORATION

Db 8.75 % perforation: front vertical grooves of 2.8 mm and blades of 13.2 mm in combination with transversed continuous slits in the core.
Blade/groove: 13.2/2.8 mm

TOP LAYER

Print HPL 0.9 mm.
On request: lacquer, veneer or digital print.

CORE

Black moisture repellent MDF.
On request: standard MDF, red or black fire retardant MDF (B-s1-d0).

TEST SETUP
IN LAB:
WALLS

TOTAL THICKNESS
90 mm

f(Hz)	T1 (s)	T2 (s)	α_s
50			
63			
80			
100	12,93	6,70	0,32
125	13,05	6,61	0,34
160	11,51	4,96	0,52
200	11,84	4,25	0,68
250	10,89	3,66	0,82
315	11,12	3,17	1,01
400	10,66	3,06	1,05
500	10,86	3,23	0,98
630	11,80	3,69	0,84
800	11,94	3,99	0,75
1000	11,58	4,33	0,65
1250	10,49	4,32	0,61
1600	8,98	4,13	0,59
2000	7,67	3,78	0,61
2500	6,13	3,32	0,63
3150	4,79	2,75	0,71
4000	3,70	2,23	0,81
5000	2,74	1,82	0,85

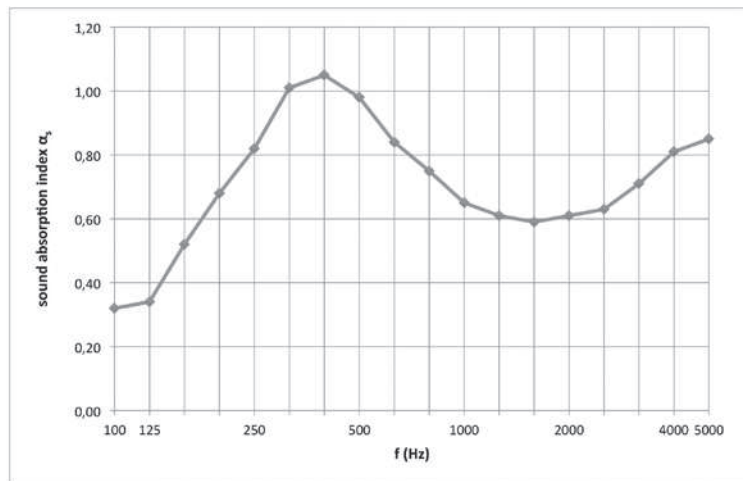

f(Hz)	α_p
125	0,40
250	0,85
500	0,95
1000	0,65
2000	0,60
4000	0,80

$\alpha_w = 0,65$ (LMH)
acoustical absorption class : C

Type Db 8.75 % 13.2/2.8 mm

To be mounted on a wooden frame with a thickness of 70 mm, filled with 50 mm of Rockfit 431 adapt 40 kg/m³.

TEST SETUP
IN LAB:
WALLS

TOTAL THICKNESS
40 mm

f(Hz)	T1 (s)	T2 (s)	α_s
50			
63			
80			
100	12,23	9,61	0,08
125	10,79	7,87	0,13
160	9,82	6,27	0,22
200	9,09	5,50	0,27
250	9,36	4,97	0,35
315	9,30	3,97	0,54
400	9,26	3,39	0,70
500	9,40	3,23	0,76
630	10,04	2,92	0,91
800	9,95	2,74	0,99
1000	9,73	2,75	0,98
1250	8,92	2,88	0,88
1600	7,72	3,02	0,76
2000	6,69	3,15	0,63
2500	5,44	3,04	0,54
3150	4,32	2,64	0,55
4000	3,40	2,16	0,62
5000	2,54	1,74	0,66

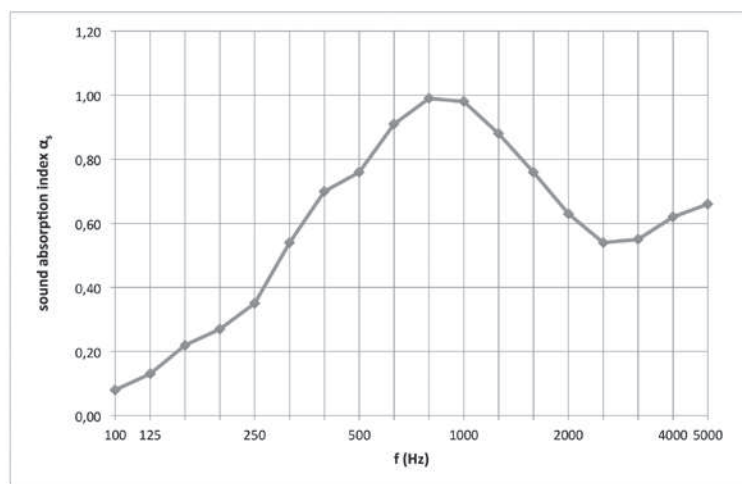

f(Hz)	α_p
125	0,15
250	0,40
500	0,80
1000	0,95
2000	0,65
4000	0,60

$\alpha_w = 0,65$ (M)
acoustical absorption class : C

Type Db 8.75 % 13.2/2.8 mm

To be mounted on a wooden frame with a thickness of 20 mm, filled with 20 mm of PRIMAWOOL 22.5 kg/m³.

TYPE Db (wall)



INSTALLATION see page 50

A core of 2 x 9 mm in black MDF with acoustic absorbing non woven glass fibre tissue in the centre.



Top layer and backing in Print HPL 0.9 mm.
(On request: lacquer, veneer or digital print.)

Type Db 8.75 % 13.2/2.8 mm

% perfo	total thickness	α_w	NRC* see page 7	SAA** see page 7
8.75 %	90 mm	0.65	0.75	0.77
	40 mm	0.65	0.70	0.69

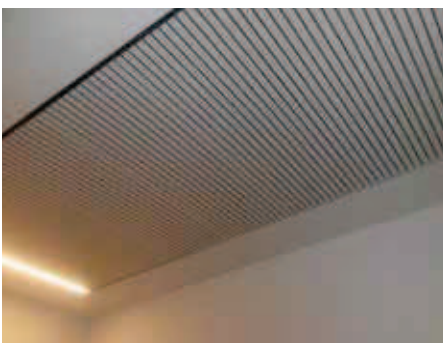

TYPE Db (door 20 mm)



2.8 mm 13.2 mm

THICKNESS +-20 mm

WEIGHT 10,5 kg/m²

MATERIAL COMPOSITION

- Core of 2 x 9 mm in MDF
- High-quality two-sided HPL finish (EN 438) of Abet Laminati
- Acoustic absorbing non woven glass fibre tissue

STD. MEASUREMENTS

Made-to-measure closet doors and sliding doors.

PERFORATION

Db 8.75 % perforation: front vertical grooves of 2.8 mm and blades of 13.2 mm in combination with transversed continuous slits in the core.
Blade/groove: 13.2/2.8 mm

TOP LAYER

Print HPL 0.9 mm.
On request: lacquer, veneer or digital print.

CORE

Black moisture repellent MDF.
On request: standard MDF, red or black fire retardant MDF (B-s1-d0).

TEST SETUP
IN LAB:
CLOSET DOORS

DEPTH
500 mm

f(Hz)	T1 (s)	T2 (s)	α_s
50			
63			
80			
100	12,65	6,70	0,27
125	10,07	3,89	0,59
160	9,14	4,02	0,53
200	9,60	4,48	0,45
250	9,25	5,32	0,30
315	9,29	5,87	0,24
400	8,86	5,17	0,31
500	9,11	4,83	0,37
630	9,79	5,52	0,30
800	9,72	5,16	0,35
1000	9,53	5,10	0,35
1250	8,69	4,89	0,35
1600	7,49	4,46	0,35
2000	6,53	4,13	0,36
2500	5,45	3,61	0,38
3150	4,40	3,08	0,42
4000	3,51	2,53	0,49
5000	2,69	2,04	0,58

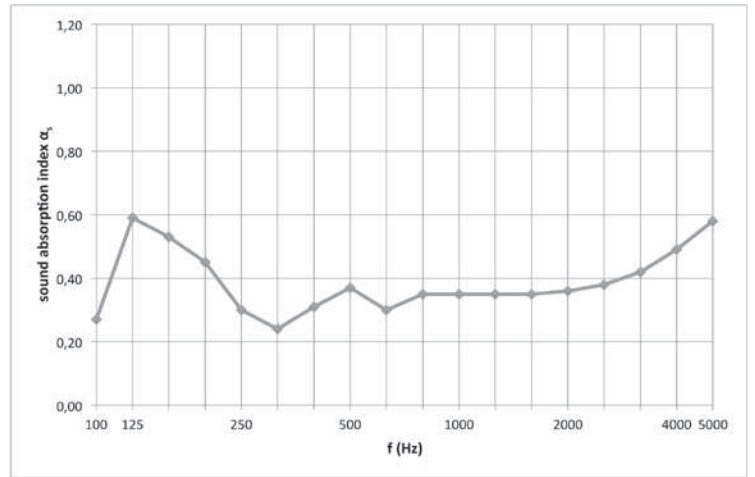

f(Hz)	α_p
125	0,45
250	0,35
500	0,35
1000	0,35
2000	0,35
4000	0,50

$\alpha_w = 0,35$ (H)
acoustical absorption class : D

Type Db 8.75 % 13.2/2.8 mm

To be mounted on a wooden frame with a height of 500 mm (= simulation of empty closet).

TEST SETUP
IN LAB:
CLOSET DOORS

DEPTH
500 mm

f(Hz)	T1 (s)	T2 (s)	α_s
50			
63			
80			
100	12,65	4,42	0,56
125	10,07	3,48	0,71
160	9,14	3,82	0,57
200	9,60	3,98	0,56
250	9,25	5,03	0,34
315	9,29	4,95	0,36
400	8,86	4,18	0,48
500	9,11	3,81	0,58
630	9,79	4,23	0,51
800	9,72	3,87	0,59
1000	9,53	3,95	0,56
1250	8,69	3,83	0,55
1600	7,49	3,62	0,54
2000	6,53	3,44	0,53
2500	5,45	3,12	0,53
3150	4,40	2,72	0,55
4000	3,51	2,32	0,58
5000	2,69	1,90	0,63

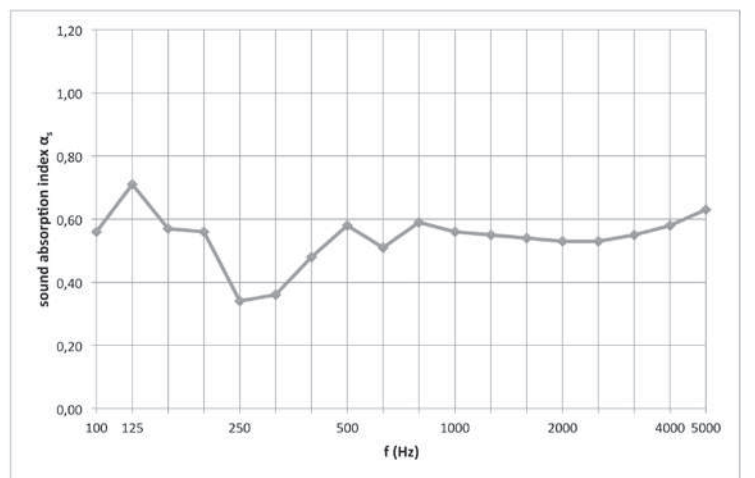

f(Hz)	α_p
125	0,60
250	0,40
500	0,50
1000	0,55
2000	0,55
4000	0,60

$\alpha_w = 0,55$ (H)
acoustical absorption class : D

Type Db 8.75 % 13.2/2.8 mm

To be mounted on a wooden frame with a height of 500 mm (= simulation of empty closet). PRIMAWOOL stuck with spun fabric side on the back of the interior of the closet.

TYPE Db (door 20 mm)



A core of 2 x 9 mm in black MDF with acoustic absorbing non woven glass fibre tissue in the centre. ABS edge band on 4 sides.



Top layer and backing in Print HPL 0.9 mm. (On request: lacquer, veneer or digital print.)

Made-to-measure for closet doors and sliding doors.



Type Db 8.75 % 13.2/2.8 mm

% perfo	total thickness	α_w	NRC* <small>see page 7</small>	SAA** <small>see page 7</small>
8.75 %	500 mm	0.35	0.35	0.34
	500 mm <small>+PRIMAWOOL</small>	0.55	0.50	0.51

TYPE Ds (wall)



2.8 mm 5.2 mm

THICKNESS +-20 mm

WEIGHT 10,5 kg/m²

MATERIAL COMPOSITION

- Core of 2 x 9 mm in MDF
- High-quality two-sided HPL finish (EN 438) of Abet Laminati
- Acoustic absorbing non woven glass fibre tissue (centre)

STD. MEASUREMENTS

- 3030 x1200 mm (veneer)
- 3030 x1280 mm (HPL)

Made-to-measure on request.

PERFORATION

Ds 17,5 % perforation: front vertical grooves of 5.2 mm and blades of 2.8 mm in combination with transversed continuous slits in the core.
Blade/groove:5.2/2.8 mm

TOP LAYER

Print HPL 0.9 mm.
On request: lacquer, veneer or digital print.

CORE

Black moisture repellent MDF.
On request: standard MDF, red or black fire retardant MDF (B-s1-d0).

TEST SETUP
IN LAB:
WALLS

TOTAL THICKNESS
90 mm

f(Hz)	T1 (s)	T2 (s)	α_s
50			
63			
80			
100	12,93	6,66	0,33
125	13,05	6,48	0,35
160	11,51	4,95	0,52
200	11,84	4,30	0,67
250	10,89	3,70	0,80
315	11,12	3,24	0,98
400	10,88	3,05	1,05
500	10,86	3,22	0,98
630	11,80	3,65	0,85
800	11,94	3,96	0,76
1000	11,58	4,27	0,67
1250	10,49	4,31	0,62
1600	8,98	4,10	0,60
2000	7,67	3,75	0,62
2500	8,13	3,25	0,65
3150	4,79	2,68	0,74
4000	3,70	2,16	0,88
5000	2,74	1,72	1,00

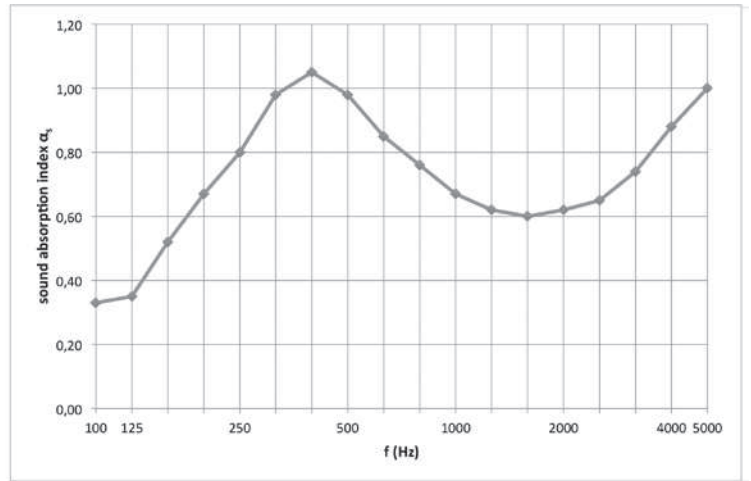

f(Hz)	α_p
125	0,40
250	0,80
500	0,95
1000	0,70
2000	0,60
4000	0,85

$\alpha_w = 0,70$ (LMH)
acoustical absorption class : C

Type Ds 17.5 % 5.2/2.8 mm

To be mounted on a wooden frame with a thickness of 70 mm, filled with 50 mm of Rockfit 431 adapt 40 kg/m³.

TEST SETUP
IN LAB:
WALLS

TOTAL THICKNESS
40 mm

f(Hz)	T1 (s)	T2 (s)	α_s
50			
63			
80			
100	12,23	9,11	0,10
125	10,79	7,52	0,15
160	9,82	6,04	0,24
200	9,09	5,26	0,30
250	9,36	4,46	0,44
315	9,30	3,80	0,58
400	9,26	3,29	0,74
500	9,40	3,19	0,78
630	10,04	2,99	0,88
800	9,95	2,80	0,96
1000	9,73	2,77	0,97
1250	8,92	2,79	0,93
1600	7,72	2,78	0,86
2000	6,69	2,80	0,78
2500	5,44	2,63	0,74
3150	4,32	2,25	0,79
4000	3,40	1,88	0,89
5000	2,54	1,50	1,02

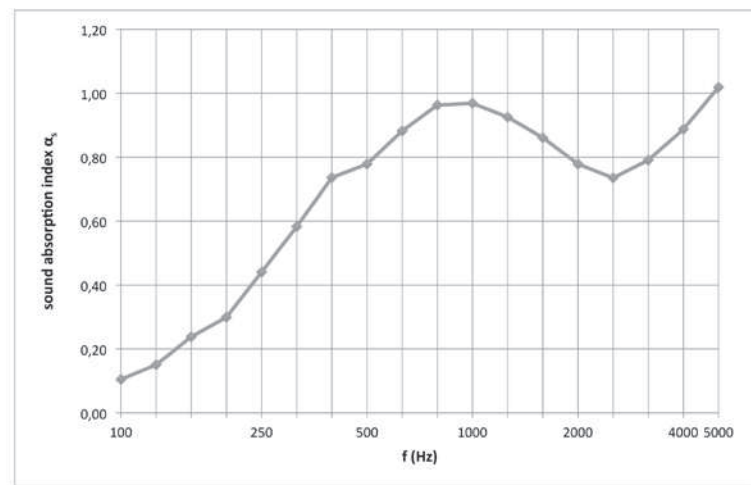

f(Hz)	α_p
125	0,15
250	0,45
500	0,80
1000	0,95
2000	0,80
4000	0,90

$\alpha_w = 0,75$ (H)
acoustical absorption class : C

Type Ds 17.5 % 5.2/2.8 mm

To be mounted on a wooden frame with a thickness of 20 mm, filled with 20 mm of PRIMAWOOL 22.5 kg/m³.

TYPE Ds (wall)



INSTALLATION see page 50

A core of 2 x 9 mm in black MDF with acoustic absorbing non woven glass fibre tissue in the centre.

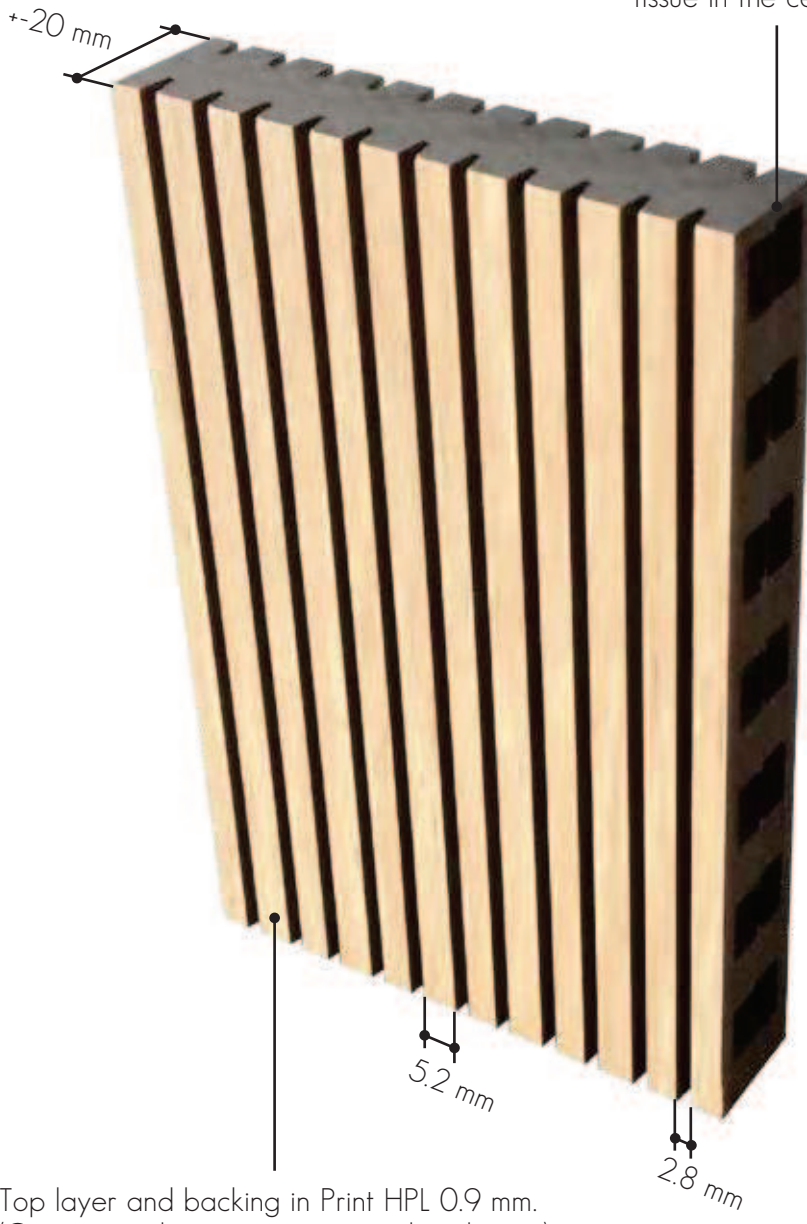

Top layer and backing in Print HPL 0.9 mm.
(On request: lacquer, veneer or digital print.)

Type Ds 17.5 % 5.2/2.8 mm

% perfo	total thickness	α_w	NRC* <small>see page 7</small>	SAA** <small>see page 7</small>
17.5 %	90 mm	0.70	0.75	0.77
	40 mm	0.75	0.75	0.75

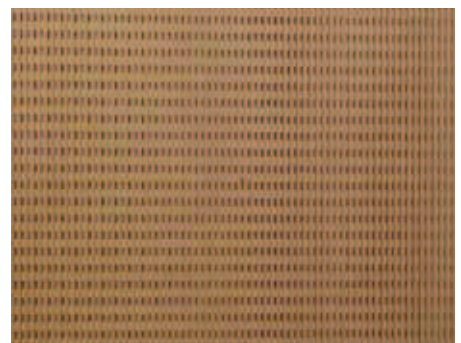
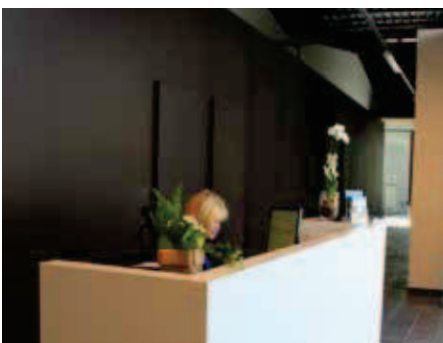

TYPE Dr (wall)

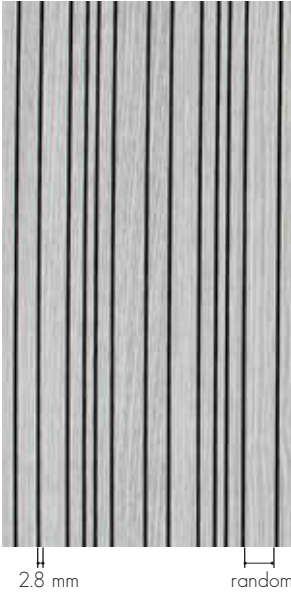

THICKNESS +-20 mm

WEIGHT 10,5 kg/m²

MATERIAL COMPOSITION

- Core of 2 x 9 mm in MDF
- High-quality two-sided HPL finish (EN 438) of Abet Laminati
- Acoustic absorbing non woven glass fibre tissue (centre)

STD. MEASUREMENTS

- 3030 x1200 mm (veneer)
- 3030 x1280 mm (HPL)

Made-to-measure on request.

PERFORATION

Dr 8.75 % perforation random with transversed continuous slits in the core. Groove: 2.8 mm

TOP LAYER

Print HPL 0.9 mm.

On request: lacquer, veneer or digital print.

CORE

Black moisture repellent MDF.

On request: standard MDF, red or black fire retardant MDF (B-s1-d0).

TEST SETUP
IN LAB:
WALLS

TOTAL THICKNESS
90 mm

f(Hz)	T1 (s)	T2 (s)	α_s
50			
63			
80			
100	12,93	6,70	0,32
125	13,05	6,61	0,34
160	11,51	4,96	0,52
200	11,84	4,25	0,68
250	10,89	3,66	0,82
315	11,12	3,17	1,01
400	10,66	3,06	1,05
500	10,86	3,23	0,98
630	11,80	3,69	0,84
800	11,94	3,99	0,75
1000	11,58	4,33	0,65
1250	10,49	4,32	0,61
1600	8,98	4,13	0,59
2000	7,67	3,78	0,61
2500	6,13	3,32	0,63
3150	4,79	2,75	0,71
4000	3,70	2,23	0,81
5000	2,74	1,82	0,85

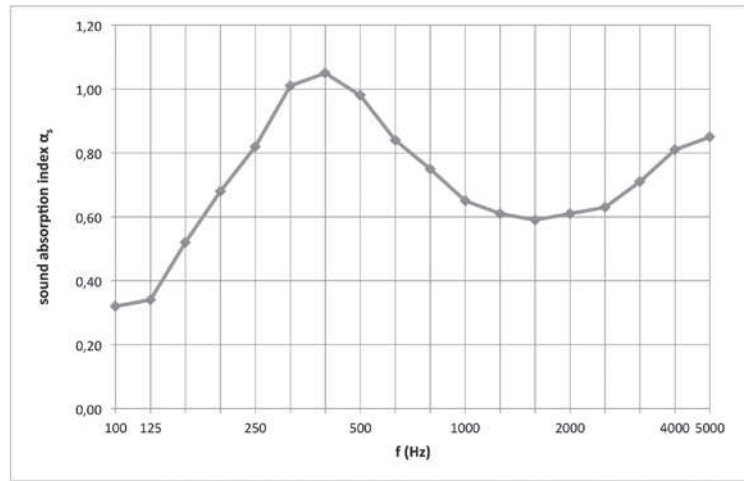

f(Hz)	α_p
125	0,40
250	0,85
500	0,95
1000	0,65
2000	0,60
4000	0,80

$\alpha_w = 0,65$ (LMH)
acoustical absorption class : C

Type Dr 8.75 % groove 2.8 mm

To be mounted on a wooden frame with a thickness of 70 mm, filled with 50 mm of Rockfit 431 adapt 40 kg/m³.

TEST SETUP
IN LAB:
WALLS

TOTAL THICKNESS
40 mm

f(Hz)	T1 (s)	T2 (s)	α_s
50			
63			
80			
100	12,23	9,61	0,08
125	10,79	7,87	0,13
160	9,82	6,27	0,22
200	9,09	5,50	0,27
250	9,36	4,97	0,35
315	9,30	3,97	0,54
400	9,26	3,39	0,70
500	9,40	3,23	0,76
630	10,04	2,92	0,91
800	9,95	2,74	0,99
1000	9,73	2,75	0,98
1250	8,92	2,88	0,88
1600	7,72	3,02	0,76
2000	6,69	3,15	0,63
2500	5,44	3,04	0,54
3150	4,32	2,64	0,55
4000	3,40	2,16	0,62
5000	2,54	1,74	0,66

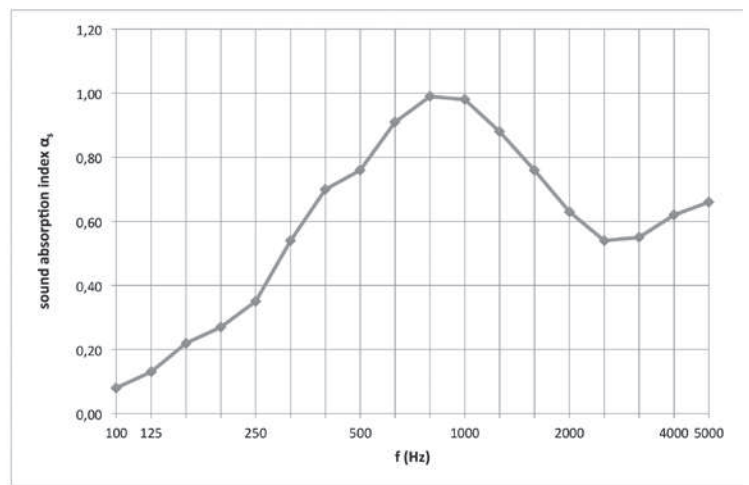

f(Hz)	α_p
125	0,15
250	0,40
500	0,80
1000	0,95
2000	0,65
4000	0,60

$\alpha_w = 0,65$ (M)
acoustical absorption class : C

Type Dr 8.75 % groove 2.8 mm

To be mounted on a wooden frame with a thickness of 20 mm, filled with 20 mm of PRIMAWOOL 22.5 kg/m³.

TYPE Dr (wall)



INSTALLATION see page 50

A core of 2 x 9 mm in black MDF with acoustic absorbing non woven glass fibre tissue in the centre.

+20 mm

random

2.8 mm

Top layer and backing in Print HPL 0.9 mm.
(On request: lacquer, veneer or digital print.)

Type Dr 8.75 % 2.8 mm

% perfo	total thickness	α_w	NRC* <small>see page 7</small>	SAA** <small>see page 7</small>
8.75 %	90 mm	0.65	0.75	0.77
	40 mm	0.65	0.70	0.69

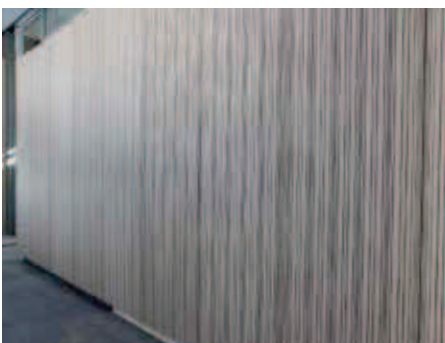

TYPE Dr (door 20 mm)

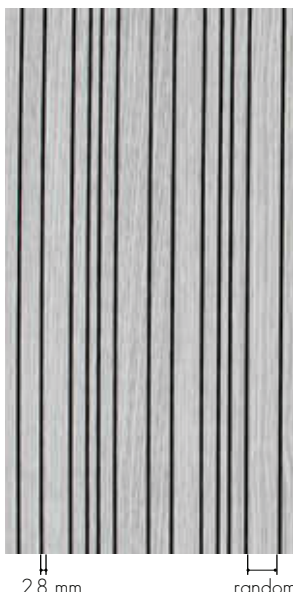

THICKNESS +-20 mm

WEIGHT 10,5 kg/m²

MATERIAL COMPOSITION

- Core of 2 x 9 mm in MDF
- High-quality two-sided HPL finish (EN 438) of Abet Laminati
- Acoustic absorbing non woven glass fibre tissue (centre)

STD. MEASUREMENTS

Made-to-measure closet doors and sliding doors.

PERFORATION

Dr 8.75 % perforation random with transversed continuous slits in the core. Groove: 2.8 mm

TOP LAYER

Print HPL 0.9 mm.
On request: lacquer, veneer or digital print.

CORE

Black moisture repellent MDF.
On request: standard MDF, red or black fire retardant MDF (B-s1-d0).

TEST SETUP
IN LAB:
CLOSET DOORS
DEPTH
500 mm

f(Hz)	T1 (s)	T2 (s)	α_s
50			
63			
80			
100	12,65	6,70	0,27
125	10,07	3,89	0,59
160	9,14	4,02	0,53
200	9,60	4,48	0,45
250	9,25	5,32	0,30
315	9,29	5,87	0,24
400	8,86	5,17	0,31
500	9,11	4,83	0,37
630	9,79	5,52	0,30
800	9,72	5,16	0,35
1000	9,53	5,10	0,35
1250	8,69	4,89	0,35
1600	7,49	4,46	0,35
2000	6,53	4,13	0,36
2500	5,45	3,61	0,38
3150	4,40	3,08	0,42
4000	3,51	2,53	0,49
5000	2,69	2,04	0,58

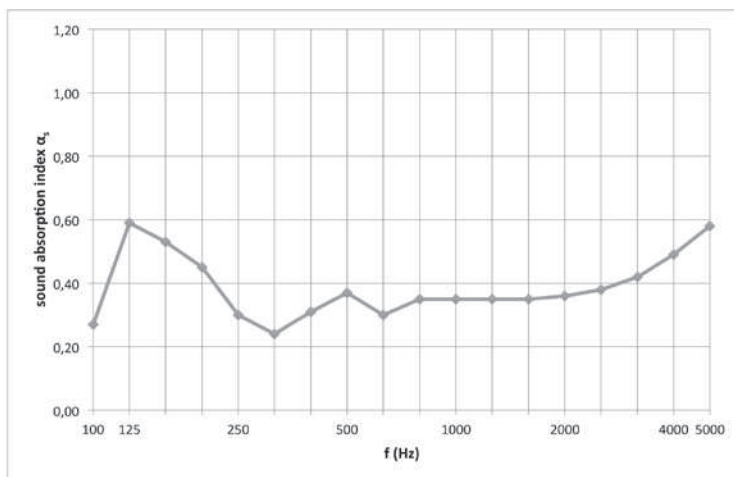

f(Hz)	α_p
125	0,45
250	0,35
500	0,35
1000	0,35
2000	0,35
4000	0,50

$\alpha_w = 0,35$ (H)
acoustical absorption class : D

Type Dr 8.75 % 13.2/2.8 mm

To be mounted on a wooden frame with a height of 500 mm (= simulation of empty closet).

TEST SETUP
IN LAB:
CLOSET DOORS
DEPTH
500 mm

f(Hz)	T1 (s)	T2 (s)	α_s
50			
63			
80			
100	12,65	4,42	0,56
125	10,07	3,48	0,71
160	9,14	3,82	0,57
200	9,60	3,98	0,56
250	9,25	5,03	0,34
315	9,29	4,95	0,36
400	8,86	4,18	0,48
500	9,11	3,81	0,58
630	9,79	4,23	0,51
800	9,72	3,87	0,59
1000	9,53	3,95	0,56
1250	8,69	3,83	0,55
1600	7,49	3,62	0,54
2000	6,53	3,44	0,53
2500	5,45	3,12	0,53
3150	4,40	2,72	0,55
4000	3,51	2,32	0,58
5000	2,69	1,90	0,63

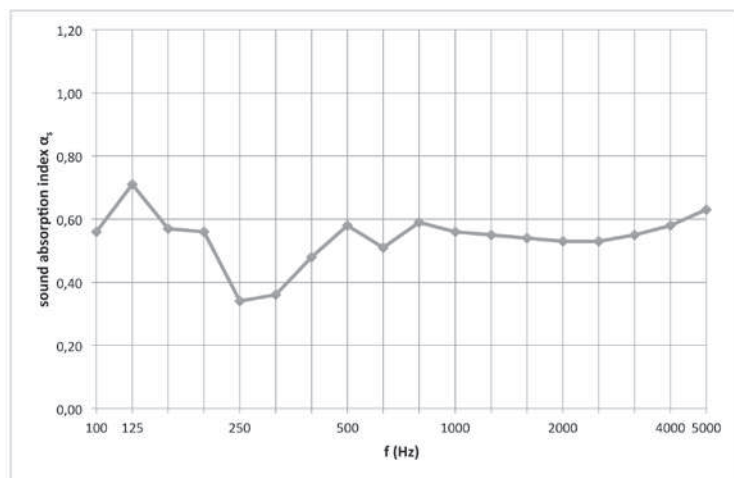

f(Hz)	α_p
125	0,60
250	0,40
500	0,50
1000	0,55
2000	0,55
4000	0,60

$\alpha_w = 0,55$ (H)
acoustical absorption class : D

Type Dr 8.75 % 13.2/2.8 mm

To be mounted on a wooden frame with a height of 500 mm (= simulation of empty closet). PRIMAWOOL stuck with spun fabric side on the back of the interior of the closet.

TYPE Dr (door 20 mm)

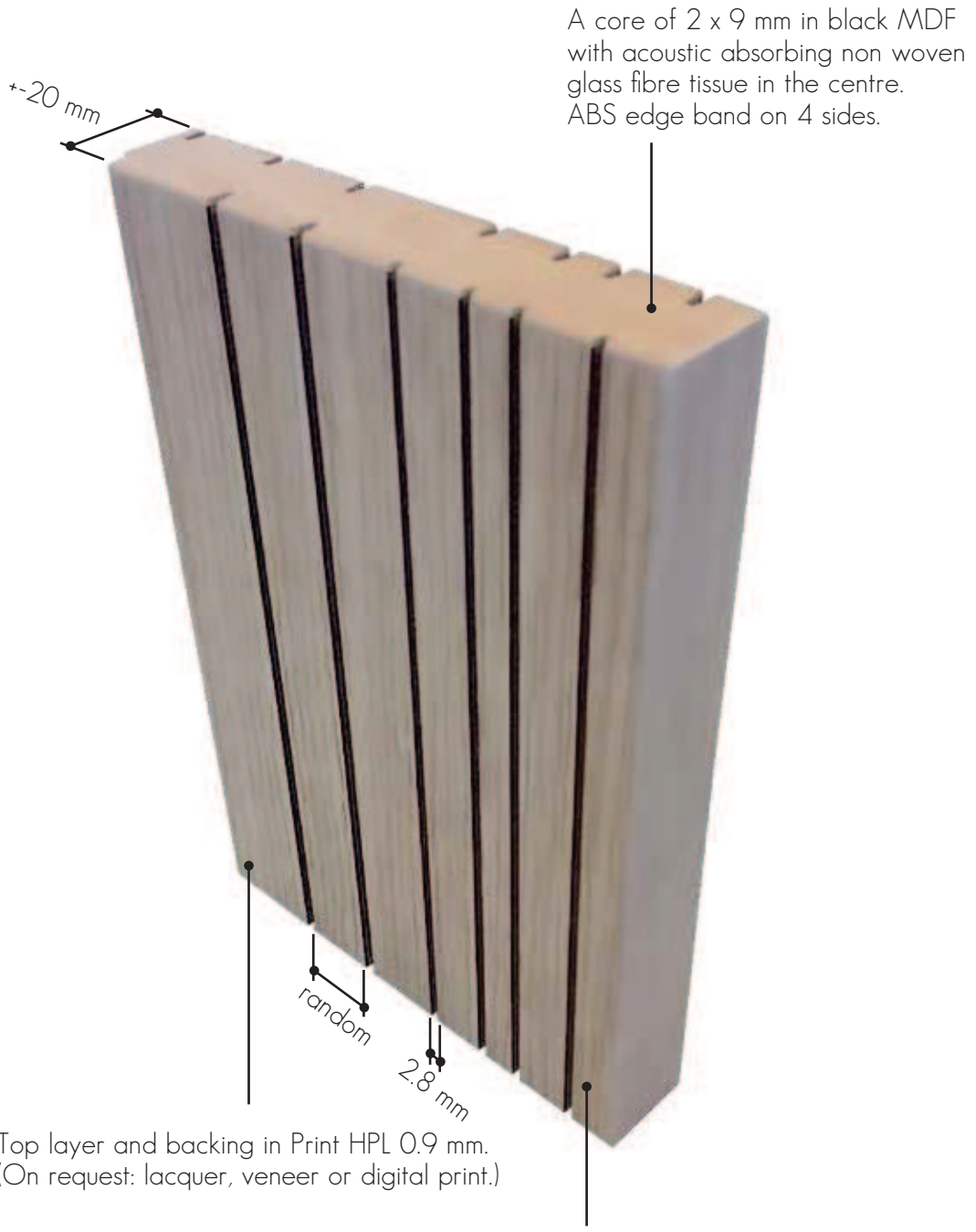

Made-to-measure for closet doors and sliding doors.



Type Dr 8.75 % 13.2/2.8 mm

% perfo	total thickness	α_w	NRC* <small>see page 7</small>	SAA** <small>see page 7</small>
8.75 %	500 mm	0.35	0.35	0.34
	500 mm <small>+PRIMAWOOL</small>	0.55	0.50	0.51

TYPE Z (wall & ceiling)



THICKNESS +-18 mm

WEIGHT 11 kg/m²

MATERIAL COMPOSITION

- Core of 16 mm in MDF
- High-quality two-sided HPL finish (EN 438) of Abet Laminati
- Acoustic absorbing non woven glass fibre tissue

STD. MEASUREMENTS

- 3030 x192 mm (tongue/groove)
- 3030 x1200 mm (veneer)
- 3030 x1280 mm (HPL)

Made-to-measure on request.

PERFORATION

Standard 16 % continuous slits
Blade/groove: 5.2/2.8 mm

TOP LAYER

Print HPL 0.9 mm.
On request: lacquer, veneer or digital print.

CORE

Black moisture repellent MDF.
On request: standard MDF, red or black fire retardant MDF (B-s1-d0).

TEST SETUP
IN LAB:
WALLS &
CEILINGS

TOTAL THICKNESS
88 mm

f(Hz)	T1 (s)	T2 (s)	α_s
50			
63			
80			
100	12,93	6,68	0,34
125	13,05	6,39	0,37
160	11,51	4,77	0,57
200	11,84	4,18	0,73
250	10,89	3,58	0,88
315	11,12	3,15	1,06
400	10,88	3,02	1,11
500	10,86	3,24	1,01
630	11,80	3,86	0,81
800	11,94	4,22	0,72
1000	11,58	4,63	0,61
1250	10,49	4,73	0,54
1600	8,98	4,56	0,51
2000	7,67	4,20	0,51
2500	8,13	3,81	0,54
3150	4,79	3,02	0,58
4000	3,70	2,47	0,64
5000	2,74	1,87	0,81

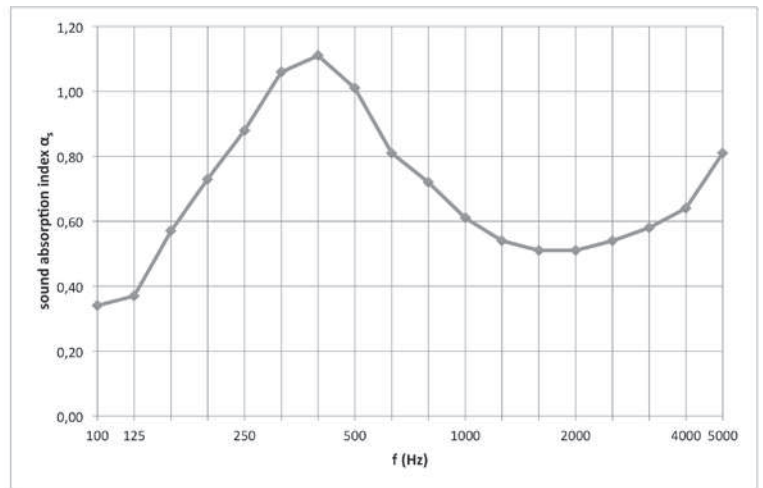

f(Hz)	α_p
125	0,45
250	0,90
500	1,00
1000	0,60
2000	0,50
4000	0,70

$\alpha_w = 0,60$ (LM)
acoustical absorption class : C

Type Z 7.5 % 23.5/8.5 mm

To be mounted on a wooden frame with a thickness of 70 mm, filled with 50 mm of Rockfit 431 adapt 40 kg/m³.

TEST SETUP
IN LAB:
WALLS &
CEILINGS

TOTAL THICKNESS
38 mm

f(Hz)	T1 (s)	T2 (s)	α_s
50			
63			
80			
100	12,23	9,20	0,10
125	10,79	7,93	0,12
160	9,82	5,95	0,25
200	9,09	5,51	0,27
250	9,36	4,61	0,41
315	9,30	3,85	0,57
400	9,26	3,46	0,68
500	9,40	3,19	0,78
630	10,04	2,98	0,88
800	9,95	2,74	0,99
1000	9,73	2,72	0,99
1250	8,92	2,75	0,94
1600	7,72	2,86	0,83
2000	6,69	2,93	0,72
2500	5,44	2,85	0,62
3150	4,32	2,52	0,61
4000	3,40	2,06	0,71
5000	2,54	1,55	0,93

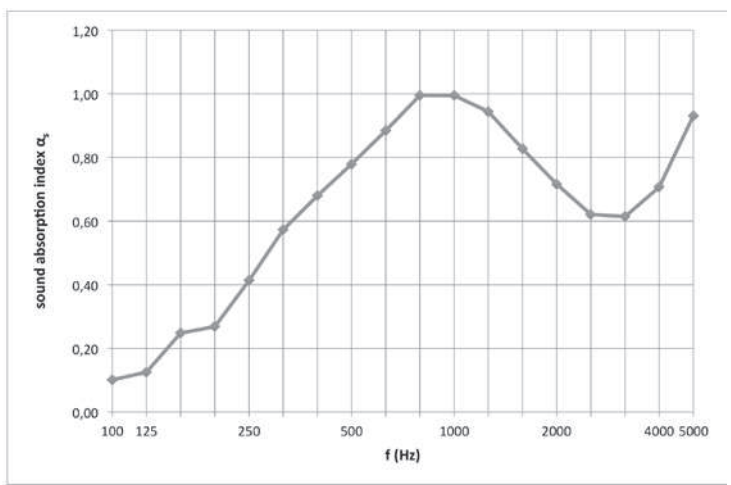

f(Hz)	α_p
125	0,15
250	0,40
500	0,80
1000	1,00
2000	0,70
4000	0,75

$\alpha_w = 0,70$ (M)
acoustical absorption class : C

Type Z 7.5 % 23.5/8.5 mm

To be mounted on a wooden frame with a thickness of 20 mm, filled with 20 mm of PRIMAWOOL 22.5 kg/m³.

TYPE Z (wall & ceiling)



INSTALLATION see page 50

A core of 16 mm in black MDF with acoustic absorbing non woven glass fibre tissue on the back.



Top layer and backing in Print HPL 0.9 mm.
(On request: lacquer, veneer or digital print.)

Type Z 7.5 % 23.5/8.5 mm

% perfo	total thickness	α_w	NRC* <small>see page 7</small>	SSAA** <small>see page 7</small>
7.5 %	88 mm	0.60	0.75	0.75
	38 mm	0.70	0.75	0.72

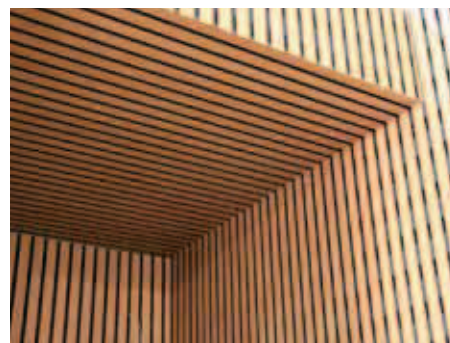

TYPE M (wall)

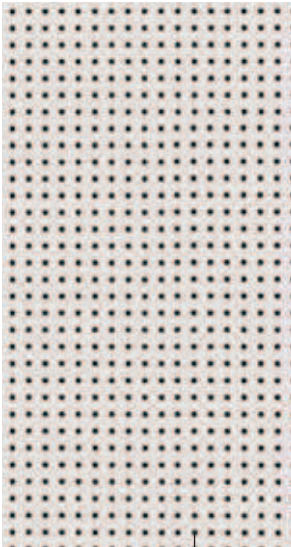

3 mm diameter 1.1 mm

THICKNESS +-20 mm

WEIGHT 11 kg/m²

MATERIAL COMPOSITION

- Core of 2 x 9 mm in MDF
- High-quality two-sided HPL finish (EN 438) of Abet Laminati
- Acoustic absorbing non woven glass fibre tissue (centre)

STD. MEASUREMENTS

- 3020 x1270 mm (HPL)
- Made-to-measure on request.

PERFORATION

Std. 4.7 % microperforations diameter 1.1 mm (linear, 3/3/1.1).

TOP LAYER

Print HPL 0.9 mm.
On request: digital print.

CORE

Black moisture repellent MDF.
On request: standard MDF, red or black fire retardant MDF (B-s1-d0).

TEST SETUP IN LAB: WALLS

TOTAL THICKNESS 90 mm

f(Hz)	T1 (s)	T2 (s)	α_s
50			
63			
80			
100	11,85	8,03	0,15
125	10,45	6,08	0,25
160	9,96	4,89	0,39
200	10,61	3,99	0,58
250	9,51	3,14	0,79
315	9,36	2,73	0,97
400	9,34	2,54	1,07
500	9,39	2,58	1,04
630	10,31	2,83	0,95
800	10,03	3,05	0,85
1000	9,78	3,13	0,81
1250	8,94	3,21	0,76
1600	7,75	3,07	0,76
2000	6,58	2,79	0,81
2500	5,29	2,47	0,88
3150	4,12	2,20	0,91
4000	3,23	1,91	0,99
5000	2,41	1,69	0,95

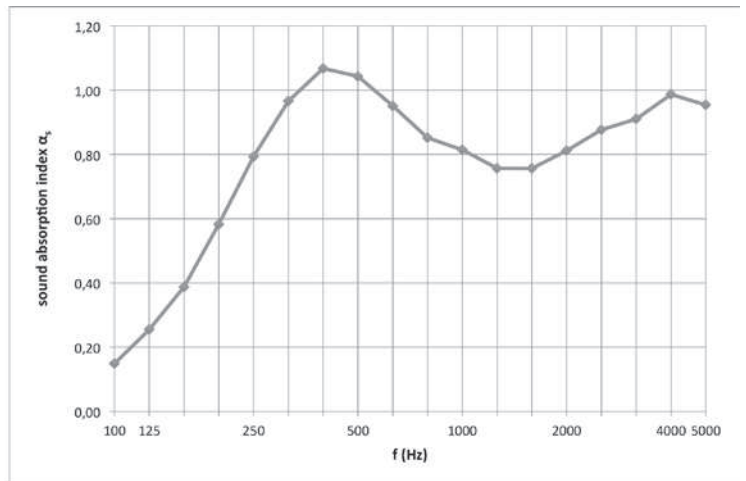

f(Hz)	α_p
125	0,25
250	0,80
500	1,00
1000	0,80
2000	0,80
4000	0,95

$\alpha_w = 0,85$ ()
acoustical absorption class : B

Type M 4.7 % 3/3/1.1

To be mounted on a wooden frame with a thickness of 70 mm, filled with 50 mm of Rockfit 431 adapt 40 kg/m³.

TEST SETUP IN LAB: WALLS

TOTAL THICKNESS 40 mm

f(Hz)	T1 (s)	T2 (s)	α_s
50			
63			
80			
100	12,23	9,64	0,08
125	10,79	7,49	0,15
160	9,82	6,41	0,20
200	9,09	5,59	0,26
250	9,36	4,78	0,38
315	9,30	3,71	0,61
400	9,26	3,30	0,73
500	9,40	3,11	0,81
630	10,04	2,87	0,94
800	9,95	2,76	0,98
1000	9,73	2,72	0,99
1250	8,92	2,73	0,95
1600	7,72	2,75	0,88
2000	6,69	2,64	0,86
2500	5,44	2,44	0,84
3150	4,32	2,11	0,90
4000	3,40	1,84	0,92
5000	2,54	1,66	0,75

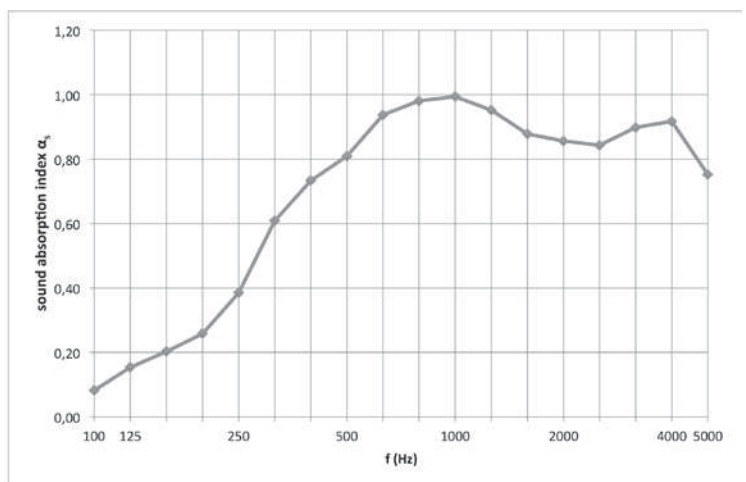

f(Hz)	α_p
125	0,15
250	0,40
500	0,85
1000	1,00
2000	0,85
4000	0,85

$\alpha_w = 0,70$ (MH)
acoustical absorption class : C

Type M 4.7 % 3/3/1.1

To be mounted on a wooden frame with a thickness of 20 mm, filled with 20 mm of PRIMAWOOL 22.5 kg/m³.

TYPE M (wall)



INSTALLATION see page 52

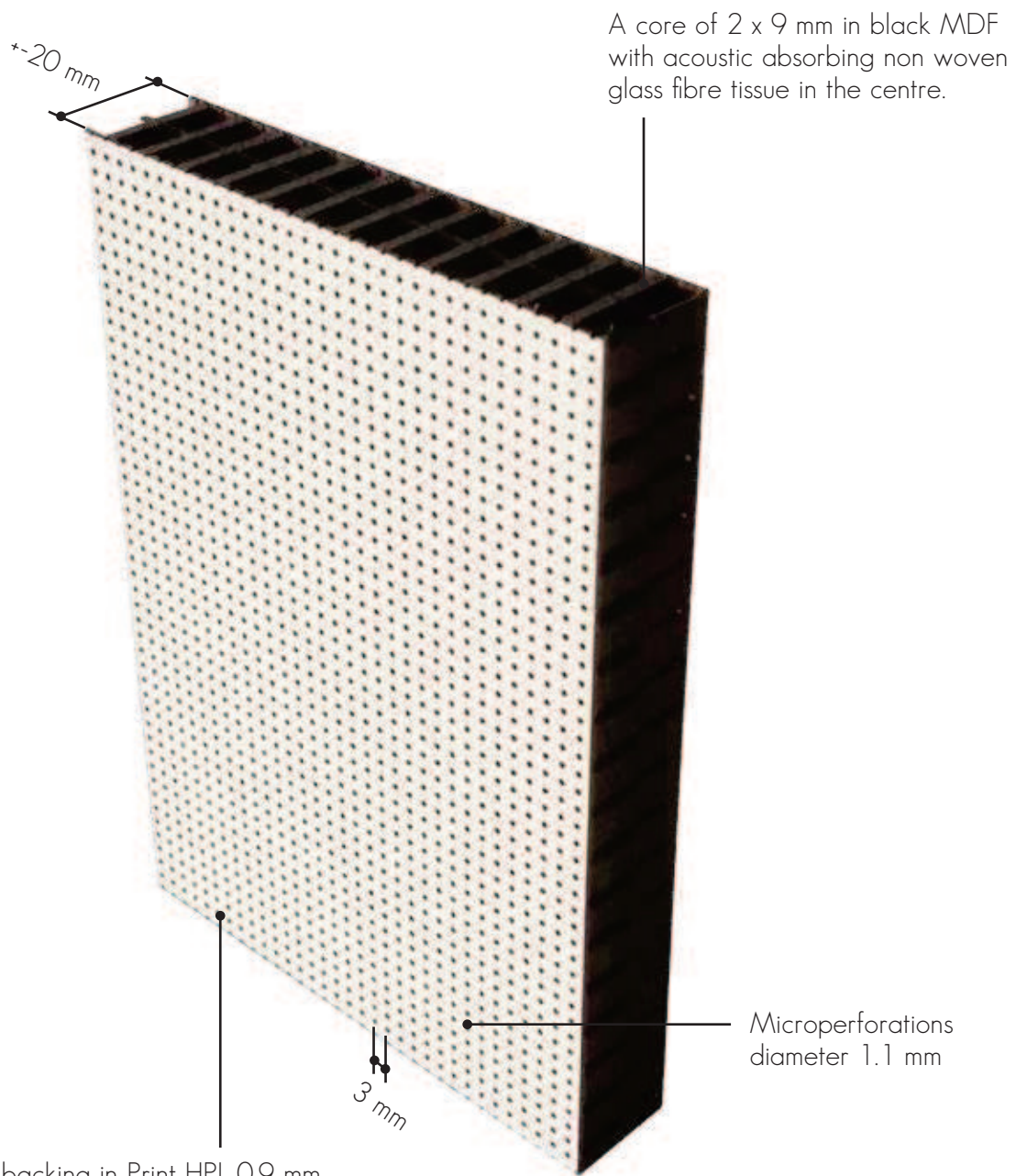

Top layer and backing in Print HPL 0.9 mm.
(On request: digital print on the front.)

Type M 4.7 % 3/3/1.1

% perfo	total thickness	α_w	NRC* <small>see page 7</small>	SAA** <small>see page 7</small>
4.7 %	90 mm	0.85	0.85	0.86
	40 mm	0.70	0.75	0.77

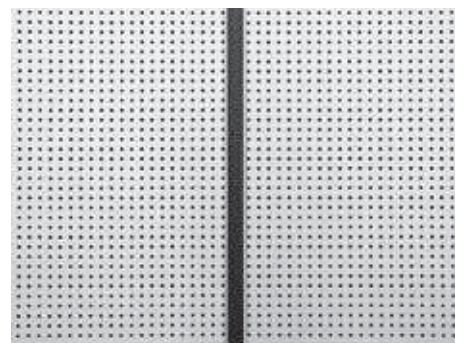

COMPOSITION OF TYPE M

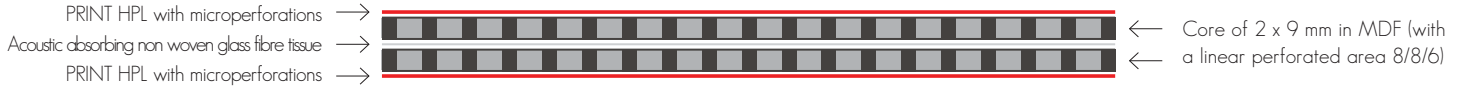

CORE: 3020 x 1270 mm

PRINT HPL LAMINATE: 3020 x 1270 mm

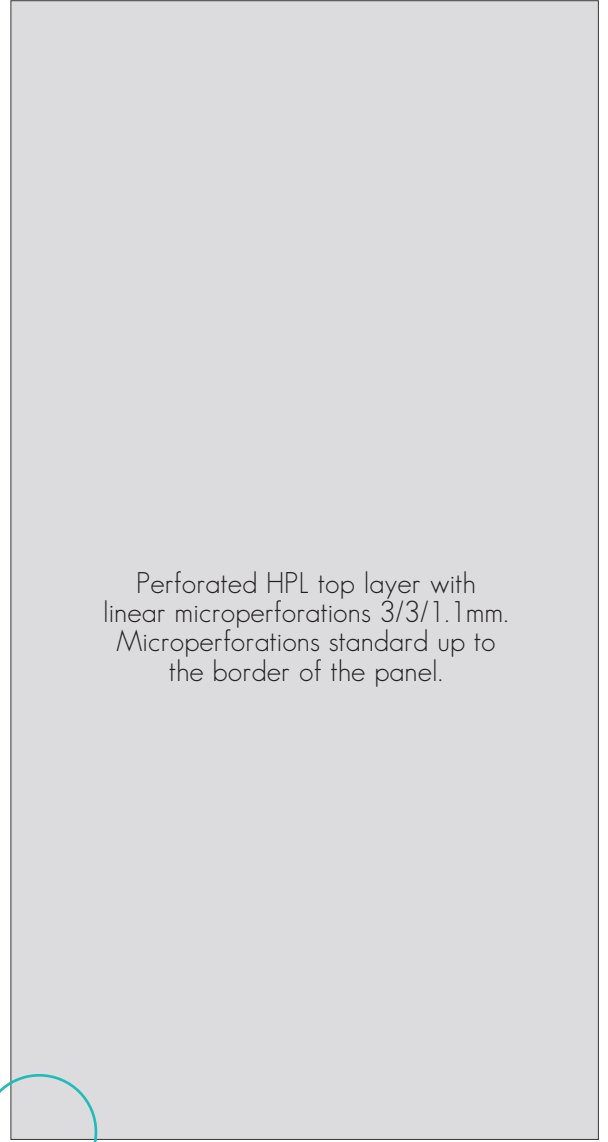
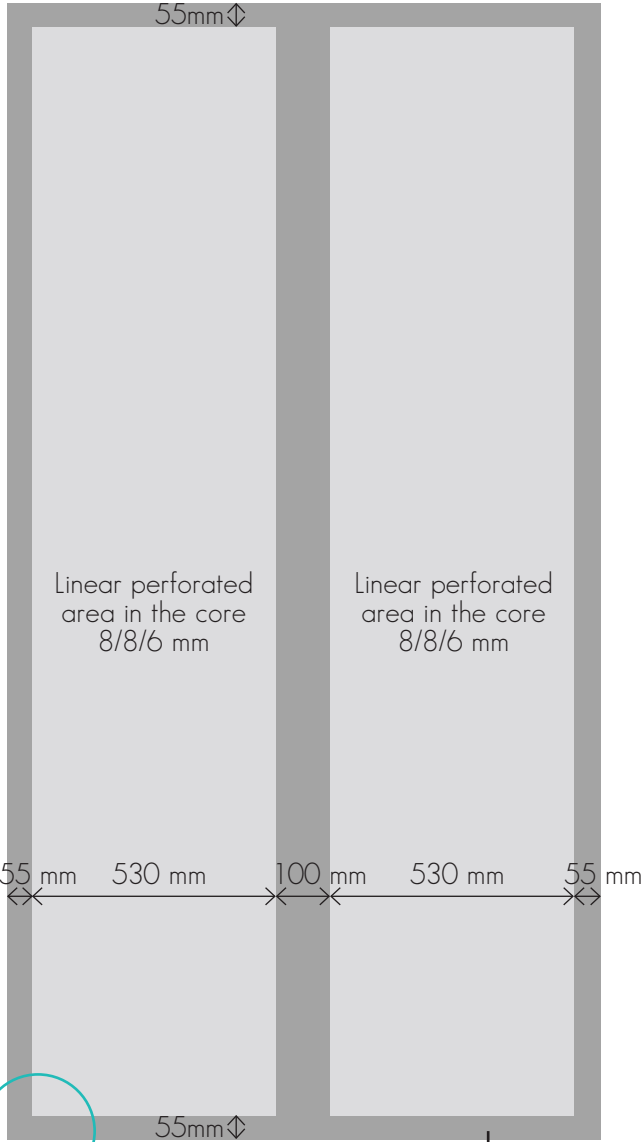

Non-perforated area around and in the centre of the panel.

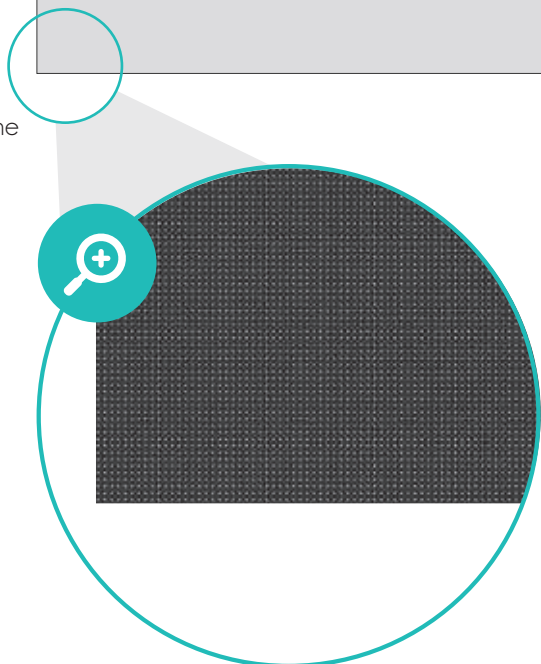
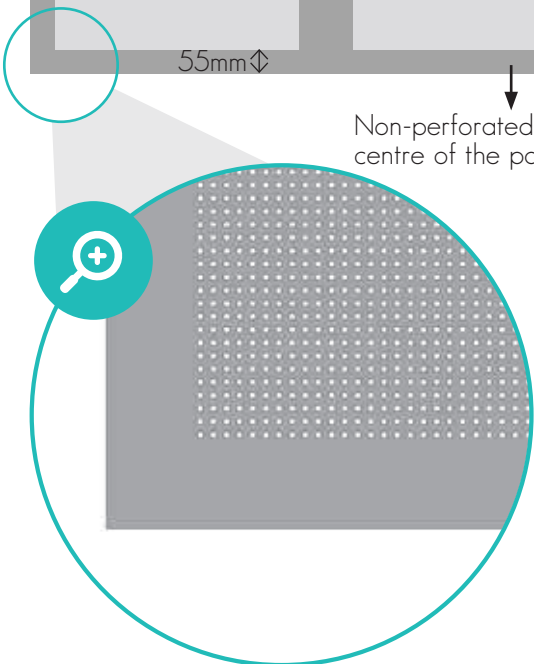

COMPOSITION OF TYPE M



CORE: 3020 x 1270 mm

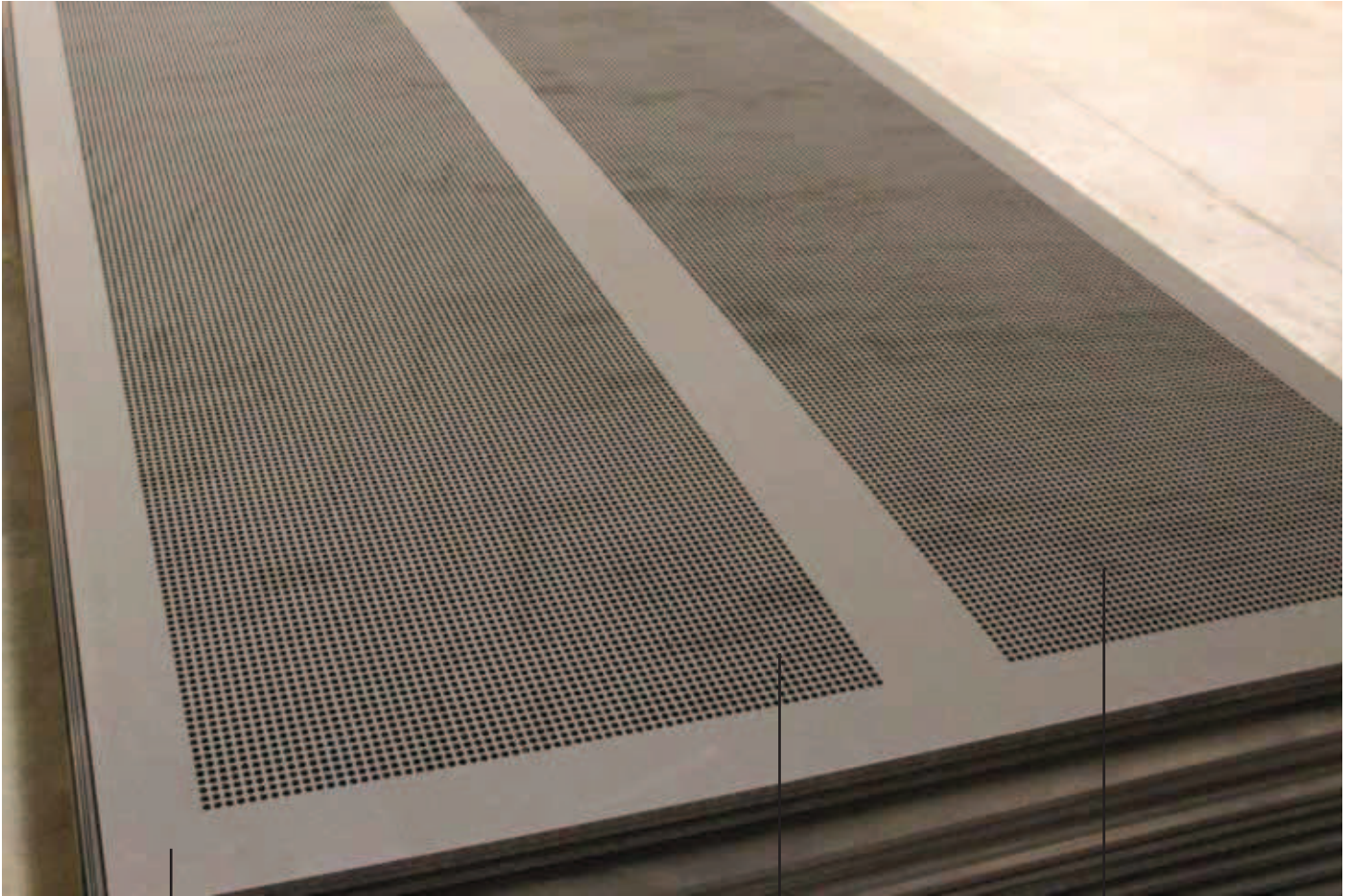

Core in standard black waterproof MDF with a non-perforated area around and in the centre of the panel.

Two perforated areas in the core (linear 8/8/6 mm).

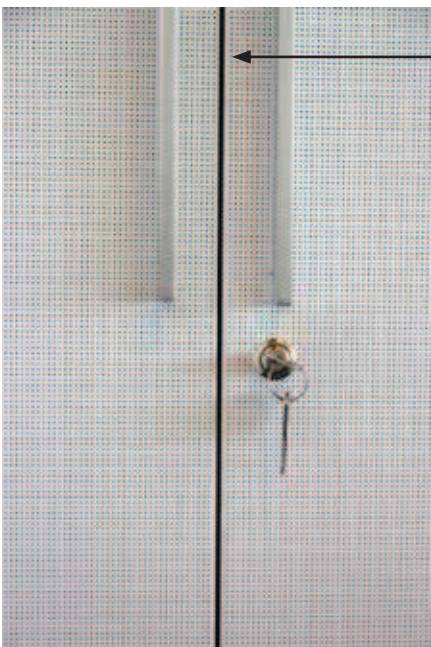

Perforated HPL top layer with linear microperforations 3/3/1.1mm. Microperforations standard up to the border of the panel.

Optionally the top layer can be ordered with a non-perforated border.



TYPE M (door 20 mm)

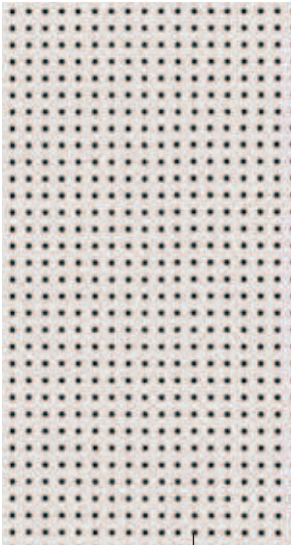

3 mm diKERNter 1.1 mm

THICKNESS +-20 mm

WEIGHT 11 kg/m²

MATERIAL COMPOSITION

- Core of 2 x 9 mm in MDF
- High-quality two-sided HPL finish (EN 438) of Abet Laminati

STD. MEASUREMENTS

Made-to-measure closet doors and sliding doors.

PERFORATION

Std. 4.7 % microperforations diameter 1.1 mm (linear, 3/3/1.1).

TOP LAYER

Print HPL 0.9 mm.
On request: digital print.

CORE

Black moisture repellent MDF.
On request: standard MDF, red or black fire retardant MDF (B-s1-d0).

TEST SETUP IN LAB: CLOSET DOORS

DEPTH 500 mm

f(Hz)	T1 (s)	T2 (s)	α_s
50			
63			
80			
100	12,65	5,24	0,42
125	10,07	3,91	0,59
160	9,14	3,38	0,71
200	9,60	3,94	0,56
250	9,25	4,90	0,36
315	9,29	5,31	0,31
400	8,86	4,47	0,42
500	9,11	4,07	0,51
630	9,79	4,47	0,46
800	9,72	4,20	0,51
1000	9,53	4,08	0,53
1250	8,69	3,80	0,56
1600	7,49	3,43	0,61
2000	6,53	3,16	0,63
2500	5,45	2,76	0,70
3150	4,40	2,38	0,77
4000	3,51	2,08	0,81
5000	2,69	1,81	0,80

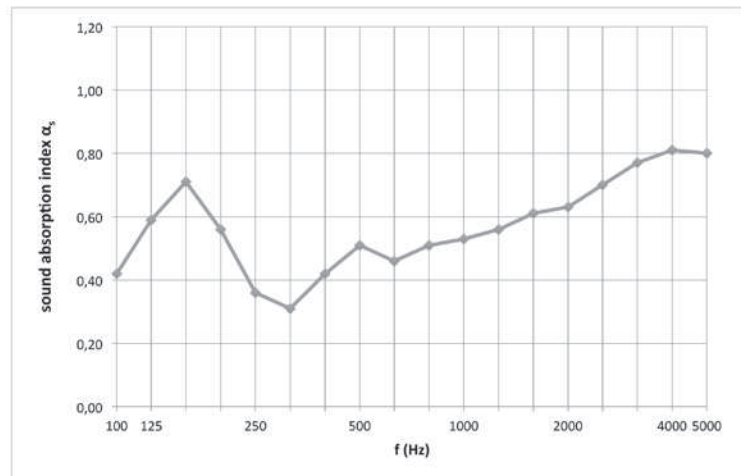

f(Hz)	α_p
125	0,55
250	0,40
500	0,45
1000	0,55
2000	0,65
4000	0,80

$\alpha_w = 0,55$ (H)
acoustical absorption class : D

Type M 4.7 % 3/3/1.1

To be mounted on a wooden frame with a height of 500 mm (= simulation of empty closet).

TEST SETUP IN LAB: CLOSET DOORS

DEPTH 500 mm

f(Hz)	T1 (s)	T2 (s)	α_s
50			
63			
80			
100	12,65	4,16	0,61
125	10,07	3,43	0,73
160	9,14	3,32	0,73
200	9,60	3,68	0,63
250	9,25	4,56	0,42
315	9,29	4,37	0,46
400	8,86	3,87	0,55
500	9,11	3,41	0,70
630	9,79	3,87	0,65
800	9,72	3,46	0,71
1000	9,53	3,39	0,72
1250	8,69	3,28	0,72
1600	7,49	3,02	0,76
2000	6,53	2,85	0,77
2500	5,45	2,56	0,81
3150	4,40	2,25	0,87
4000	3,51	2,01	0,89
5000	2,69	1,80	0,84

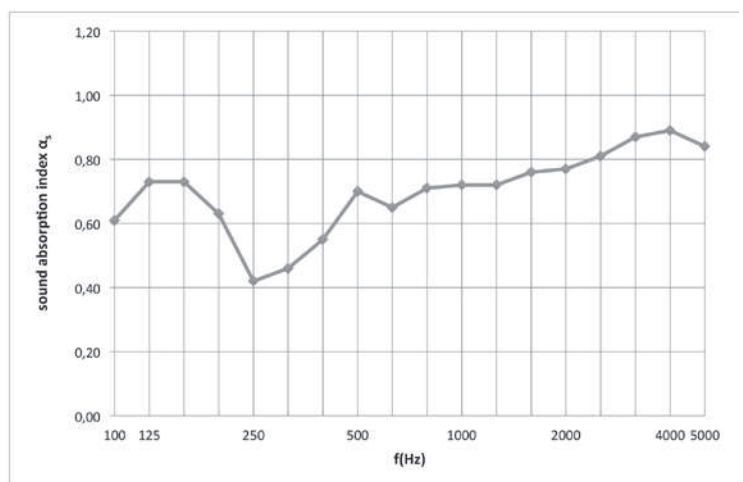

f(Hz)	α_p
125	0,70
250	0,50
500	0,65
1000	0,70
2000	0,80
4000	0,85

$\alpha_w = 0,70$ (H)
acoustical absorption class : C

Type M 4.7 % 3/3/1.1

To be mounted on a wooden frame with a height of 500 mm (= simulation of empty closet). PRIMAWOOL stuck with spun fabric side on the back of the interior of the closet.

TYPE M (door 20 mm)

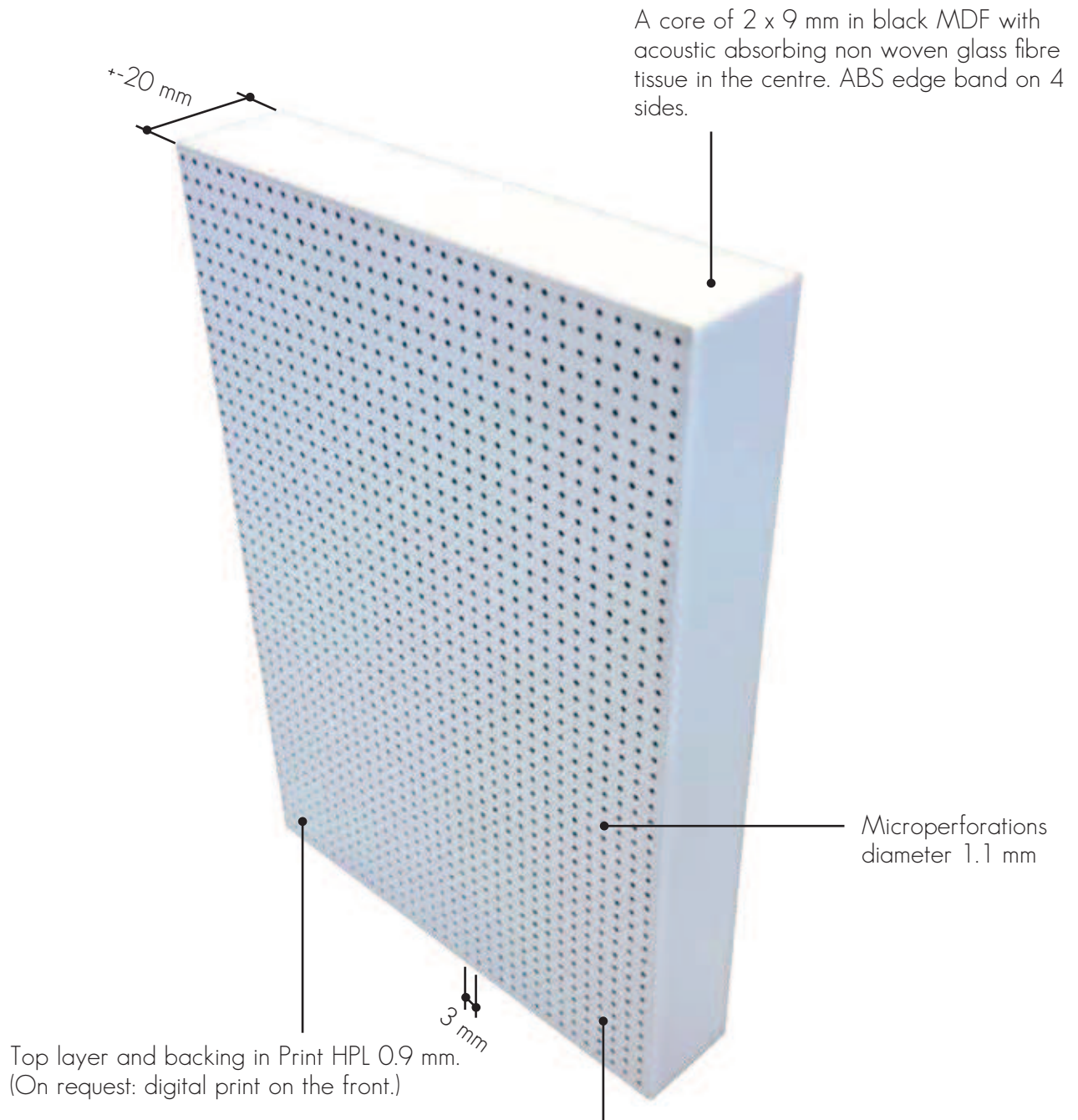

Made-to-measure for closet doors and sliding doors.



Type M 4.7 % 3/3/1.1

% perfo	total thickness	α_w	NRC* <small>see page 7</small>	SAA** <small>see page 7</small>
4.7 %	500 mm	0.55	0.50	0.51
	500 mm <small>-PRIMAWOOL</small>	0.70	0.65	0.66

TYPE T (wall)



THICKNESS +/-18 mm

WEIGHT 11,5 kg/m²

MATERIAL COMPOSITION

- Core of 16 mm in MDF
- High-quality two-sided HPL finish (EN 438) of Abet Laminati
- Acoustic absorbing non woven glass fibre tissue

STD. MEASUREMENTS

- 3008 x1280 mm
- 576 x 576 mm (4-sided milled)

Made-to-measure on request.

PERFORATION

Standard 6.8 % mosaic design. Blade/groove: 29.8/2.2 mm. The perforations are following each other horizontally and vertically: infinitely repeating!

TOP LAYER

Print HPL 0.9 mm.
On request: lacquer, veneer or digital print.

CORE

Black moisture repellent MDF.
On request: standard MDF, red or black fire retardant MDF (B-s1-d0).

TEST SETUP IN LABO WALLS

TOTAL THICKNESS
88 mm

f(Hz)	T1 (s)	T2 (s)	α_s
50			
63			
80			
100	12,21	7,87	0,17
125	11,52	5,64	0,34
160	9,98	5,31	0,33
200	9,84	3,86	0,59
250	9,09	3,00	0,83
315	9,32	2,67	1,00
400	9,12	2,64	1,01
500	9,15	2,71	0,97
630	9,95	2,86	0,93
800	9,83	3,18	0,80
1000	9,55	3,54	0,67
1250	8,79	3,69	0,60
1600	7,60	3,59	0,56
2000	6,49	3,39	0,54
2500	5,28	3,07	0,54
3150	4,14	2,64	0,55
4000	3,26	2,22	0,60
5000	2,43	1,72	0,73

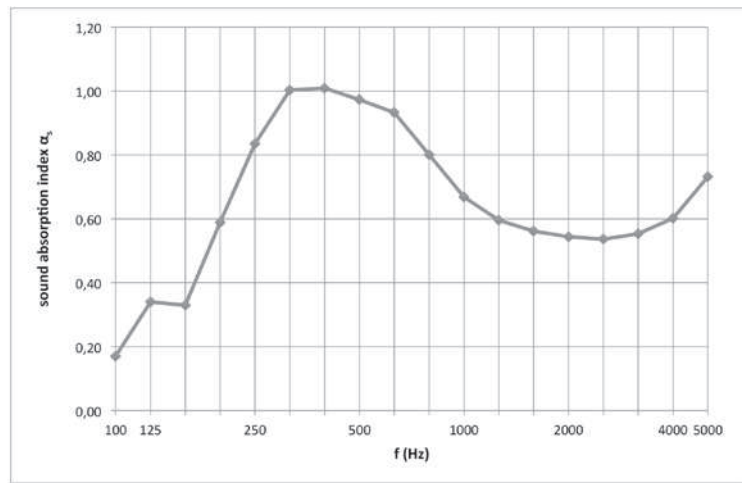

f(Hz)	α_p
125	0,30
250	0,80
500	0,95
1000	0,70
2000	0,55
4000	0,65

$\alpha_w = 0,65$ (LM)
acoustical absorption class : C

Type T 6.8 % 29.8/2.2 mm

To be mounted on a wooden frame with a thickness of 70 mm, filled with 50 mm of Rockfit 431 adapt 40 kg/m³.

TEST SETUP IN LAB: WALLS

TOTAL THICKNESS
38 mm

f(Hz)	T1 (s)	T2 (s)	α_s
50			
63			
80			
100	12,12	8,57	0,13
125	11,73	7,38	0,19
160	10,10	7,04	0,16
200	10,15	5,74	0,28
250	9,26	4,64	0,40
315	9,28	4,00	0,53
400	9,11	3,63	0,62
500	9,36	3,20	0,76
630	10,04	3,01	0,86
800	9,93	2,83	0,94
1000	9,68	2,70	0,99
1250	8,97	2,78	0,92
1600	7,85	2,82	0,84
2000	6,82	2,93	0,72
2500	5,58	2,84	0,64
3150	4,46	2,57	0,61
4000	3,53	2,18	0,65
5000	2,66	1,74	0,73

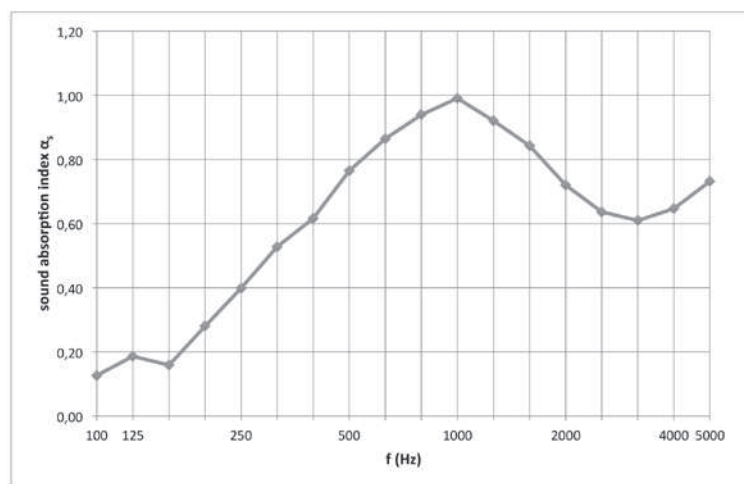

f(Hz)	α_p
125	0,15
250	0,40
500	0,75
1000	0,95
2000	0,75
4000	0,65

$\alpha_w = 0,70$ (M)
acoustical absorption class : C

Type T 6.8 % 29.8/2.2 mm

To be mounted on a wooden frame with a thickness of 20 mm, filled with 20 mm of PRIMAWOOL 22.5 kg/m³.

TYPE T (wall)



INSTALLATION see page 50

A core of 16 mm in black MDF with acoustic absorbing non woven glass fibre tissue on the back.



Top layer and backing in Print HPL 0.9 mm.
(On request: lacquer, veneer or digital print.)

Type T 6.8 % 29.8/2.2 mm

% perfo	total thickness	α_w	NRC* <small>see page 7</small>	SAA** <small>see page 7</small>
6.8 %	88 mm	0.65	0.75	0.75
	38 mm	0.70	0.70	0.71

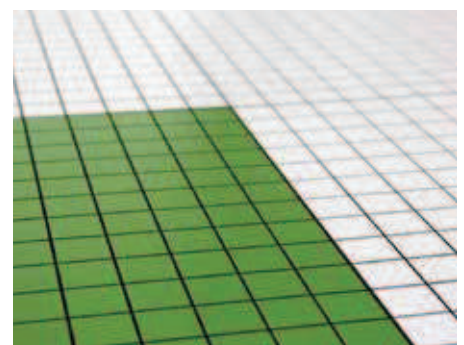
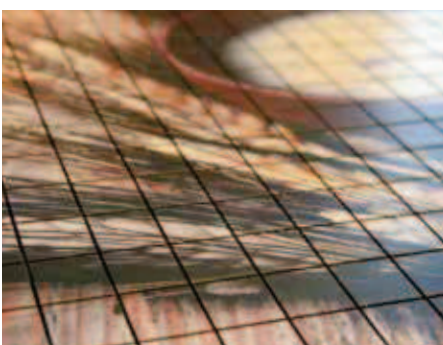

TYPE I (wall 10 mm)

PATENT PENDING

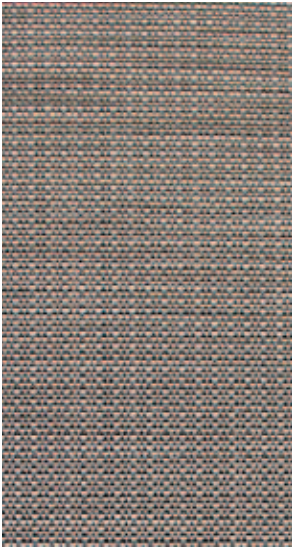

THICKNESS +/-10 mm

WEIGHT 6 kg/m²

MATERIAL COMPOSITION

- Core of 9 mm in MDF
- High-quality woven vinyl of Ntgrate®
- Acoustic absorbing non woven glass fibre tissue

STD. MEASUREMENTS

- 3030 x 640 mm
- Made-to-measure on request.

PERFORATION

Woven vinyl. Invisible design.

TOP LAYER

Ntgrate® woven vinyl 1 mm.

CORE

Black moisture repellent MDF.
On request: standard MDF, red or black fire retardant MDF (B-s1-d0).

TEST SETUP IN LAB: WALLS

TOTAL THICKNESS 80 mm

f(Hz)	T1 (s)	T2 (s)	α _s
50			
63			
80			
100	12,57	7,40	0,21
125	12,83	6,53	0,28
160	10,20	5,07	0,37
200	10,76	4,12	0,56
250	9,66	3,26	0,76
315	9,50	2,81	0,94
400	9,44	2,74	0,97
500	9,29	2,70	0,98
630	10,38	2,75	1,00
800	10,33	2,91	0,92
1000	10,02	2,97	0,88
1250	9,19	2,97	0,85
1600	8,04	2,88	0,83
2000	6,92	2,67	0,85
2500	5,67	2,42	0,88
3150	4,50	2,21	0,85
4000	3,54	1,97	0,82
5000	2,68	1,63	0,87

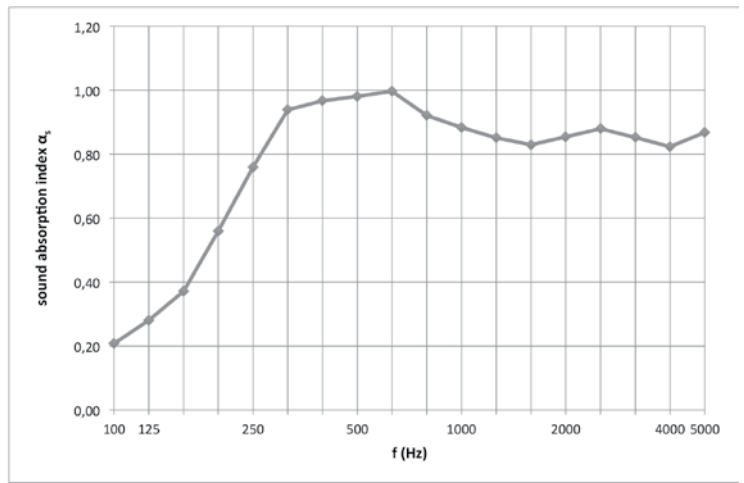

f(Hz)	α _p
125	0,30
250	0,75
500	1,00
1000	0,90
2000	0,85
4000	0,85

aw = 0,90 ()
acoustical absorption class : A Type I

To be mounted on a wooden frame with a thickness of 70 mm, filled with 50 mm of Rockfit 431 adapt 40 kg/m³.

TEST SETUP IN LAB: WALLS

TOTAL THICKNESS 30 mm

f(Hz)	T1 (s)	T2 (s)	α _s
50			
63			
80			
100	11,86	9,95	0,06
125	10,87	8,70	0,09
160	9,83	7,33	0,13
200	10,35	6,21	0,24
250	9,94	5,34	0,32
315	9,36	4,64	0,41
400	9,27	4,08	0,51
500	9,64	3,72	0,62
630	10,57	3,48	0,72
800	10,39	3,24	0,79
1000	10,08	3,04	0,86
1250	9,15	2,85	0,91
1600	7,94	2,69	0,92
2000	6,68	2,55	0,91
2500	5,35	2,36	0,90
3150	4,16	2,15	0,87
4000	3,26	1,91	0,85
5000	2,42	1,59	0,87

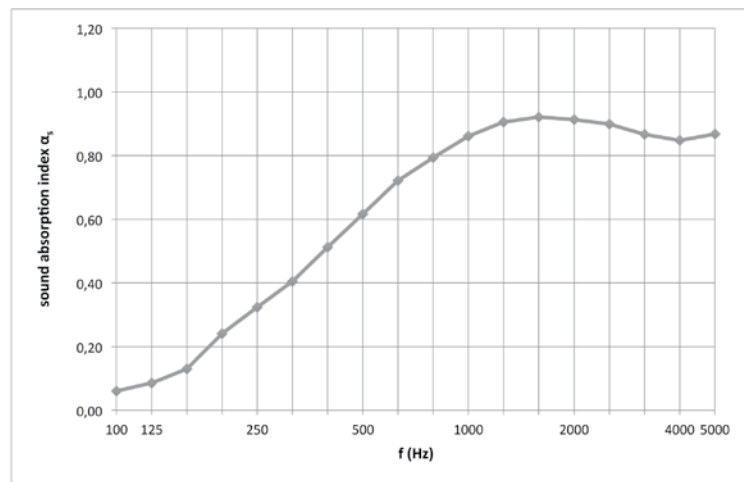

f(Hz)	α _p
125	0,10
250	0,30
500	0,60
1000	0,85
2000	0,90
4000	0,85

aw = 0,60 (MHH)
acoustical absorption class : c Type I

To be mounted on a wooden frame with a thickness of 20 mm, filled with 20 mm of PRIMAWOOL 22.5 kg/m³.

TYPE I (wall 10 mm)

INSTALLATION see page 51

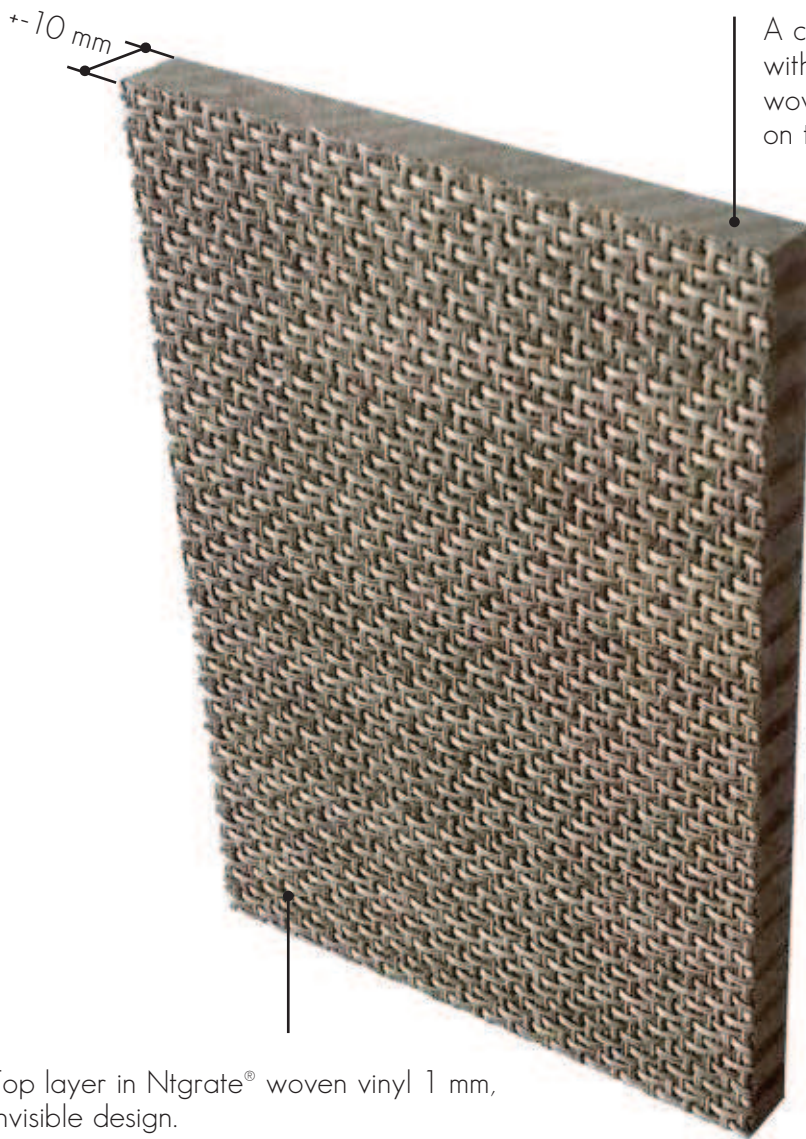

A core of 9 mm in black MDF with acoustic absorbing non woven glass fibre tissue on the back.

Top layer in Ntgrate® woven vinyl 1 mm, invisible design.

**PATENT
PENDING**

% perfo	total thickness	α_w	NRC* <small>see page 7</small>	SAA** <small>see page 7</small>
Technical textile	80 mm	0.90	0.85	0.87
	30 mm	0.60	0.70	0.68

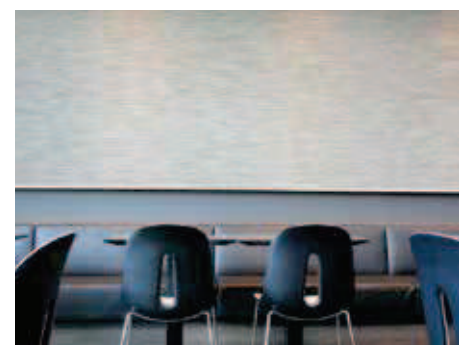

TYPE I (door 18 mm)

**PATENT
PENDING**

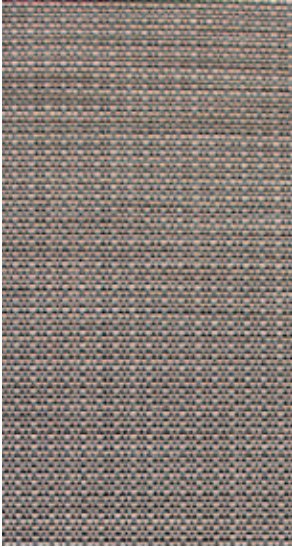

THICKNESS +-18 mm

WEIGHT 11 kg/m²

MATERIAL COMPOSITION

- Core of 16 mm in MDF
- High-quality woven vinyl of Ntgrate®

STD. MEASUREMENTS

Made-to-measure closet doors and sliding doors.

PERFORATION

Woven vinyl. Invisible design.

TOP LAYER

Ntgrate® woven vinyl 1 mm.

CORE

Black moisture repellent MDF.

On request: standard MDF, red or black fire retardant MDF (B-s1-d0).

TEST SETUP
IN LAB:
CLOSET DOORS

DEPTH
500 mm

f(Hz)	T1 (s)	T2 (s)	α_s
50			
63			
80			
100	12,65	4,87	0,48
125	10,07	3,90	0,59
160	9,14	4,10	0,51
200	9,60	4,71	0,41
250	9,25	5,68	0,26
315	9,29	5,72	0,26
400	8,86	5,15	0,31
500	9,11	4,70	0,39
630	9,79	5,14	0,35
800	9,72	4,84	0,39
1000	9,53	4,66	0,42
1250	8,69	4,35	0,44
1600	7,49	3,93	0,47
2000	6,53	3,62	0,48
2500	5,45	3,20	0,52
3150	4,40	2,79	0,54
4000	3,51	2,41	0,56
5000	2,69	1,97	0,63

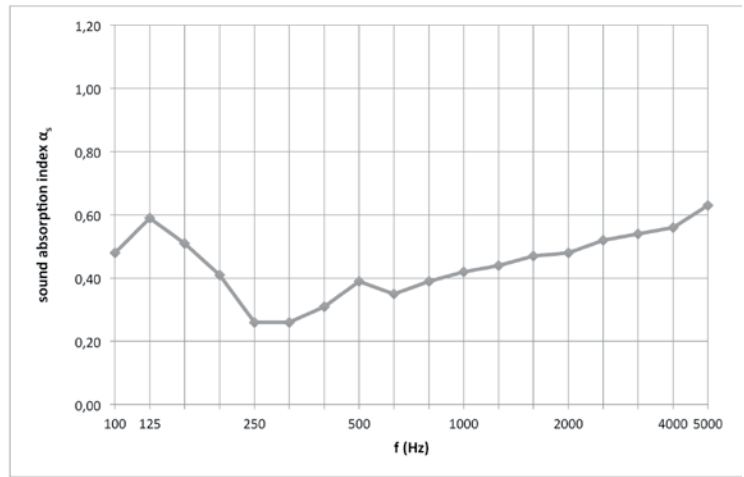

f(Hz)	α_p
125	0,55
250	0,30
500	0,35
1000	0,40
2000	0,50
4000	0,60

$\alpha_w = 0,40$ (H)
acoustical absorption class : D

Type I

To be mounted on a wooden frame with a height of 500 mm (= simulation of empty closet).

TEST SETUP
IN LAB:
CLOSET DOORS

DEPTH
500 mm

f(Hz)	T1 (s)	T2 (s)	α_s
50			
63			
80			
100	12,93	6,70	0,47
125	13,05	6,61	0,52
160	11,51	4,96	0,59
200	11,84	4,25	0,57
250	10,89	3,66	0,38
315	11,12	3,17	0,38
400	10,66	3,06	0,50
500	10,86	3,23	0,64
630	11,80	3,69	0,59
800	11,94	3,99	0,67
1000	11,58	4,33	0,68
1250	10,49	4,32	0,70
1600	8,98	4,13	0,73
2000	7,67	3,78	0,75
2500	6,13	3,32	0,76
3150	4,79	2,75	0,79
4000	3,70	2,23	0,81
5000	2,74	1,82	0,86

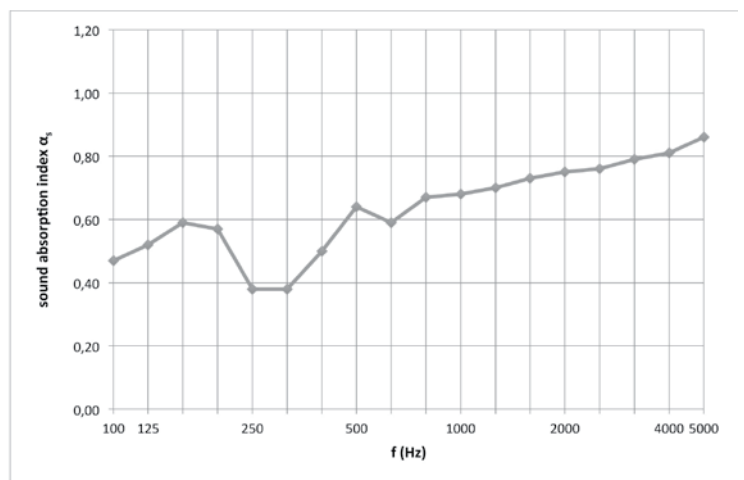

f(Hz)	α_p
125	0,40
250	0,85
500	0,95
1000	0,65
2000	0,60
4000	0,80

$\alpha_w = 0,65$ (LMH)
acoustical absorption class : c

Type I

To be mounted on a wooden frame with a height of 500 mm (= simulation of empty closet). PRIMAWOOL stuck with spun fabric side on the back of the interior of the closet.

TYPE I (door 18 mm)



A core of 16 mm in black MDF with ABS edge band.

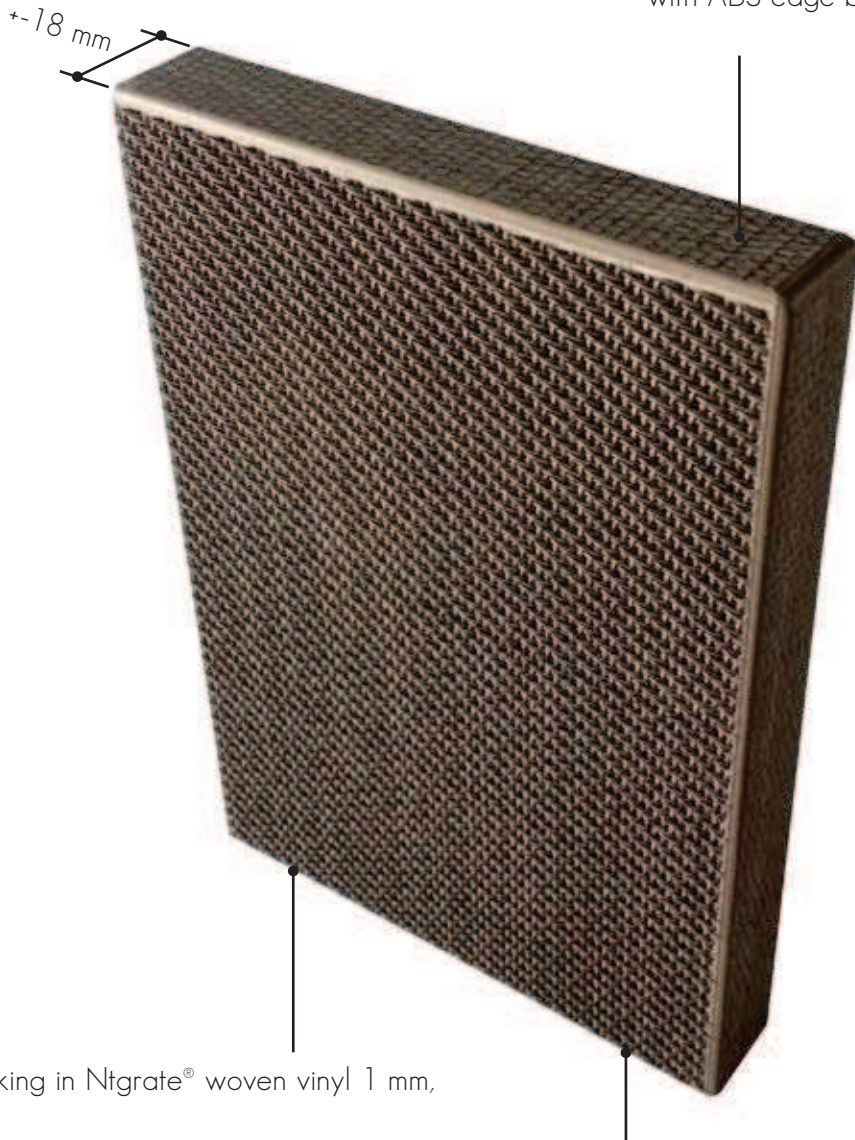

Top layer & backing in Ntgrate® woven vinyl 1 mm, invisible design.

Made-to-measure for closet doors and sliding doors.

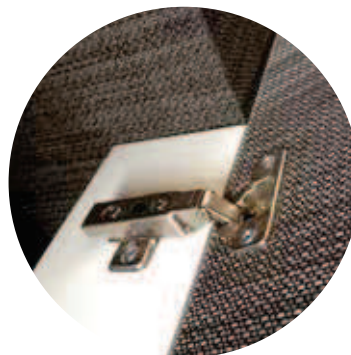

PATENT PENDING

% perfo	total thickness	α_w	NRC* <small>see page 7</small>	SAA** <small>see page 7</small>
Technical textile	500mm	0.40	0.40	0.39
	500mm <small>+PRIMA WOOL</small>	0.65	0.60	0.61

TYPE C (wall)

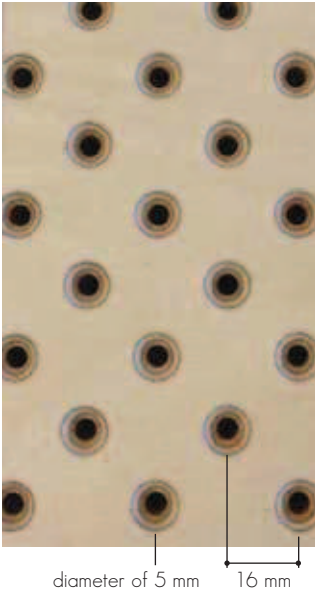

THICKNESS +-18 mm

WEIGHT 10 kg/m²

MATERIAL COMPOSITION

- Core of 18 mm in MX
- Acoustic absorbing non woven glass fibre tissue

STD. MEASUREMENTS

- 3040 x 1280 mm

PERFORATION

Std 7.7%. Type C16d 5/23/23. Chanfrein 12 mm.
Made-to-measure on request.

OPTIONAL

Toplayer in HPL possible.

TEST SETUP
IN LAB:
WALLS

TOTAL THICKNESS
88 mm

f(Hz)	T1 (s)	T2 (s)	α_s
50			
63			
80			
100	12,46	7,29	0,21
125	12,44	5,12	0,43
160	9,04	4,36	0,44
200	8,77	3,40	0,67
250	8,73	2,72	0,94
315	8,74	2,54	1,04
400	8,78	2,65	0,98
500	9,02	2,98	0,83
630	9,71	3,55	0,66
800	9,55	4,06	0,53
1000	9,17	4,51	0,42
1250	8,24	4,71	0,34
1600	7,14	4,58	0,30
2000	6,03	4,30	0,27
2500	4,85	3,82	0,24
3150	3,76	3,24	0,21
4000	2,93	2,69	0,20
5000	2,18	2,07	0,23

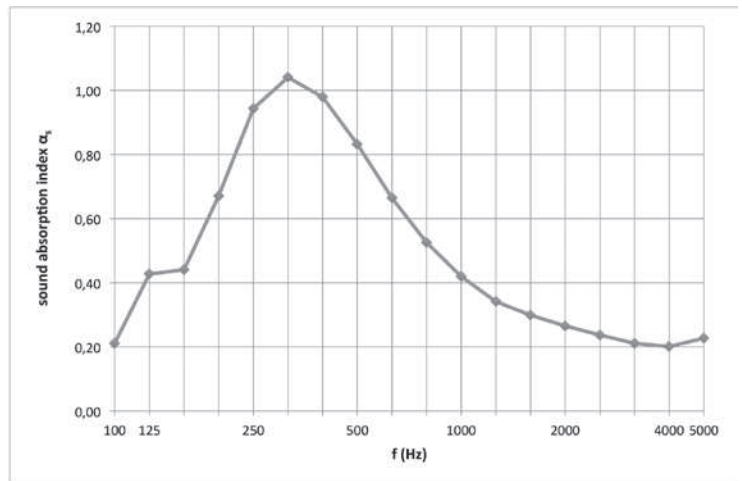

f(Hz)	α_p
125	0,35
250	0,90
500	0,85
1000	0,45
2000	0,25
4000	0,20

$a_w = 0,30$ (LM)
acoustical absorption class : D

Type C 7.7 % C16d 5/23/23

To be mounted on a wooden frame with a thickness of 70 mm, filled with 50 mm of Rockfit 431 adapt 40 kg/m³.

TEST SETUP
IN LAB:
WALLS

TOTAL THICKNESS
38 mm

f(Hz)	T1 (s)	T2 (s)	α_s
50			
63			
80			
100	12,23	9,12	0,10
125	10,79	8,00	0,12
160	9,82	6,13	0,23
200	9,09	5,56	0,26
250	9,36	4,57	0,42
315	9,30	3,75	0,59
400	9,26	3,26	0,74
500	9,40	2,92	0,88
630	10,04	2,79	0,96
800	9,95	2,89	0,91
1000	9,73	3,34	0,73
1250	8,92	3,71	0,58
1600	7,72	3,88	0,47
2000	6,69	3,84	0,41
2500	5,44	3,54	0,36
3150	4,32	3,04	0,35
4000	3,40	2,51	0,37
5000	2,54	1,94	0,43

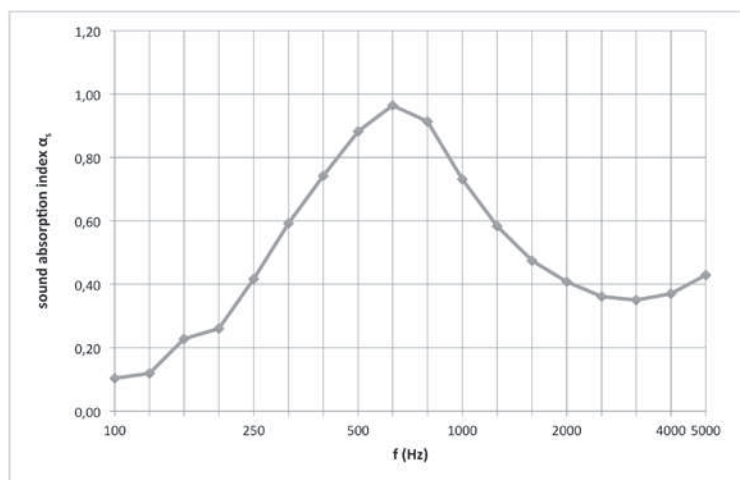

f(Hz)	α_p
125	0,15
250	0,40
500	0,85
1000	0,75
2000	0,40
4000	0,40

$a_w = 0,50$ (MM)
acoustical absorption class : D

Type C 7.7 % C16d 5/23/23

To be mounted on a wooden frame with a thickness of 20 mm, filled with 20 mm of PRIMAWOOL 22.5 kg/m³.

TYPE C (wall)



INSTALLATION see page 52

A core of 18 mm in MX with acoustic absorbing non woven glass fibre tissue on the back.



Type C16d: drilled holes with a diameter of 5 mm with chanfrein 12 mm, each one at a distance of 23 mm from each other.

Type C 7.7% C16d 5/23/23

% perfo	total thickness	α_w	NRC* <small>see page 7</small>	SAA** <small>see page 7</small>
7.7 %	88 mm	0.30	0.60	0.60
	38 mm	0.50	0.60	0.61

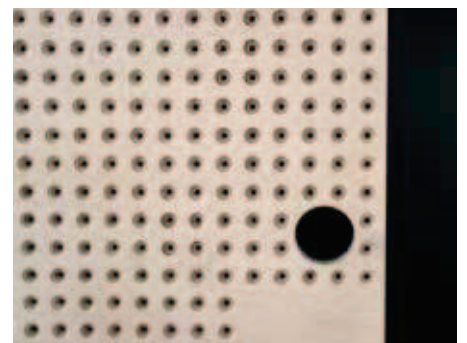
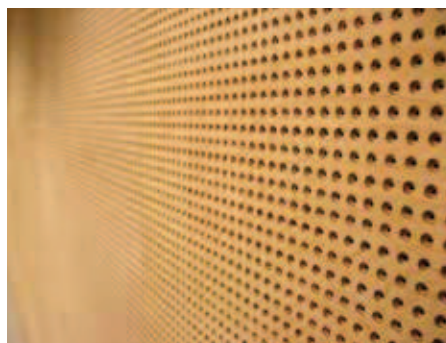

TYPE B (wall)



Type 16/16/5

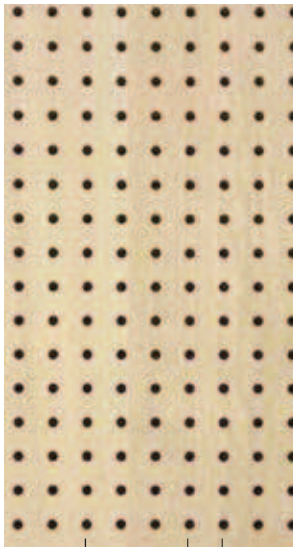

diameter of 5 mm 16 mm

THICKNESS +-18 mm

WEIGHT 12 kg/m²

MATERIAL COMPOSITION

- Core of 16 mm in MDF
- High-quality two-sided HPL finish (EN 438) of Abet Laminati
- Acoustic absorbing non woven glass fibre tissue

STD. MEASUREMENTS

- 3040 x1280 mm
- Made-to-measure on request.

TOP LAYER

Print HPL 0.9 mm.
On request: lacquer, veneer or digital print.

PERFORATION

Dobo= Drilled holes / **perfo**= degree of perforation.

- Dobo 16 x 16 x 5 mm | perfo 7.7 %
- Dobo 16 x 16 x 6 mm | perfo 11.0 %
- **Dobo 16 x 16 x 8 mm | perfo 19.6 %**
- Dobo 16 x 16 x 10 mm | perfo 30.7 %
- Dobo 32 x 32 x 6 mm | perfo 2.8 %
- Dobo 32 x 32 x 8 mm | perfo 4.9 %
- Dobo 32 x 32 x 10 mm | perfo 7.7 %

CORE

Black moisture repellent MDF.
On request: standard MDF, red or black fire retardant MDF (B-s1-d0). Multiplex birch or poplar.

TEST SETUP
IN LAB:
WALLS

TOTAL THICKNESS
88 mm

f(Hz)	T1 (s)	T2 (s)	α _s
50			
63			
80			
100	11,92	7,45	0,19
125	9,12	5,00	0,34
160	10,10	4,96	0,38
200	9,86	3,89	0,58
250	9,20	3,21	0,75
315	9,25	2,72	0,97
400	9,10	2,65	0,99
500	9,19	2,73	0,96
630	10,06	2,91	0,91
800	9,81	3,18	0,79
1000	9,57	3,42	0,70
1250	9,06	3,62	0,62
1600	8,12	3,63	0,57
2000	7,25	3,50	0,55
2500	6,16	3,31	0,52
3150	5,20	3,01	0,52
4000	4,31	2,67	0,53
5000	3,40	2,18	0,61

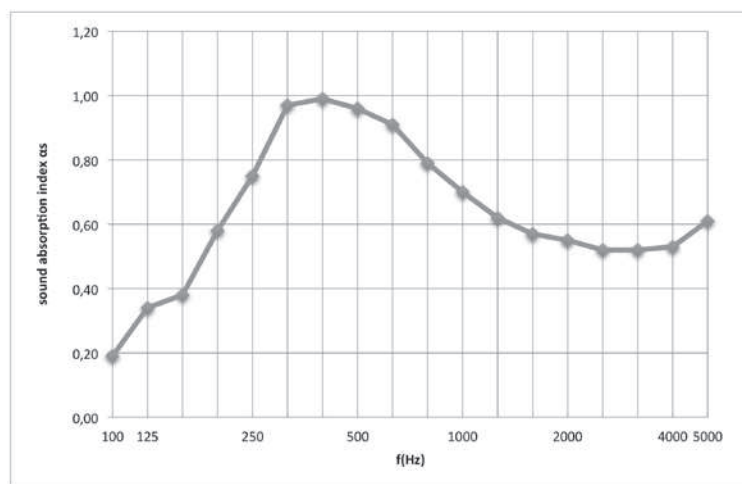

f(Hz)	α _p
125	0,30
250	0,75
500	0,95
1000	0,70
2000	0,55
4000	0,55

α_w = 0,65 (LM)
acoustical absorption class : C

Type B 19.6 % 16 x 16 x 8 mm

To be mounted on a wooden frame with a thickness of 70 mm, filled with 50 mm of Rockfit 431 adapt 40 kg/m³.

TEST SETUP
IN LAB:
WALLS

TOTAL THICKNESS
38 mm

f(Hz)	T1 (s)	T2 (s)	α _s
50			
63			
80			
100	11,92	9,41	0,08
125	9,12	6,79	0,14
160	10,10	6,68	0,19
200	9,86	5,72	0,27
250	9,20	5,10	0,33
315	9,25	4,31	0,46
400	9,10	3,61	0,62
500	9,19	3,30	0,72
630	10,06	3,07	0,84
800	9,81	2,84	0,93
1000	9,57	2,74	0,97
1250	9,06	2,77	0,93
1600	8,12	2,90	0,82
2000	7,25	3,05	0,70
2500	6,16	3,06	0,61
3150	5,20	2,88	0,57
4000	4,31	2,59	0,56
5000	3,40	2,11	0,65

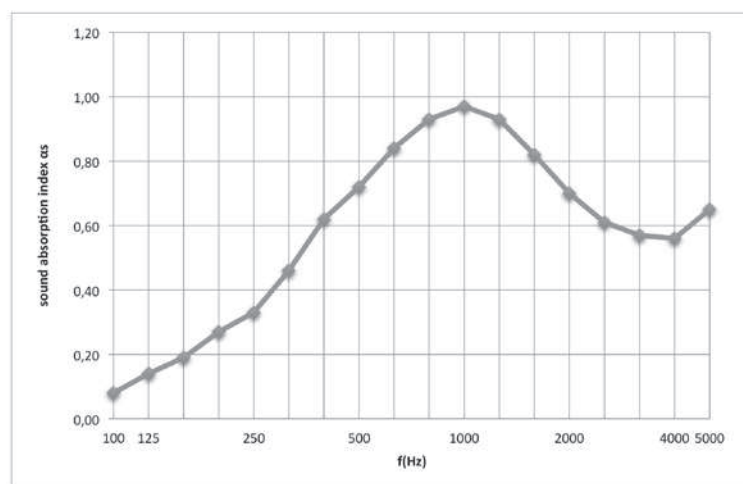

f(Hz)	α _p
125	0,15
250	0,35
500	0,75
1000	0,95
2000	0,70
4000	0,60

α_w = 0,65 (M)
acoustical absorption class : C

Type B 19.6 % 16 x 16 x 8 mm

To be mounted on a wooden frame with a thickness of 20 mm, filled with 20 mm of PRIMAWOOL 22.5 kg/m³.

TYPE B (wall)



INSTALLATION see page 52

A core of 16 mm in black MDF with acoustic absorbing non woven glass fibre tissue on the back.

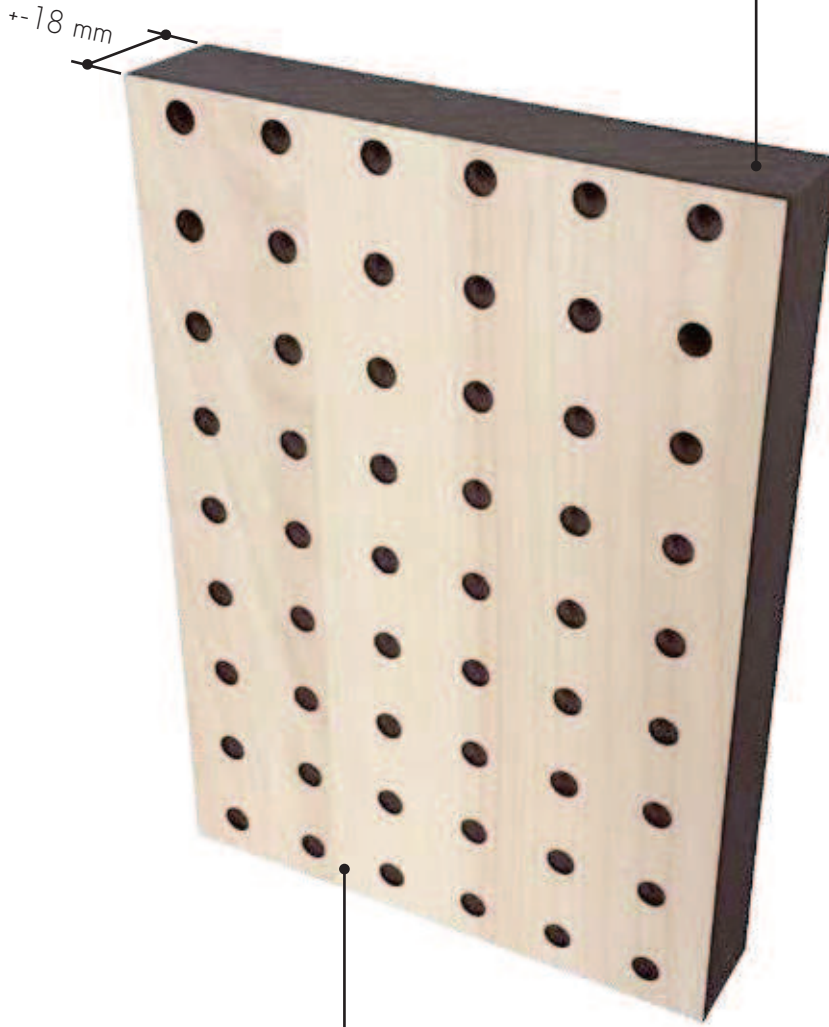

Drilled holes.
Distance between the holes should be a multiplicity of 16 or 32 mm.
Diameter at choice.

Type B 19.6 % 16 x 16 x 8 mm

% perfo	total thickness	α_w	NRC* <small>see page 7</small>	SAA** <small>see page 7</small>
19.6 %	88 mm	0.65	0.75	0.74
	38 mm	0.65	0.70	0.68



TYPE W (wall)



THICKNESS +-18 mm

WEIGHT 12 kg/m²

MATERIAL COMPOSITION

- Core of 16 mm in MDF
- High-quality two-sided HPL finish (EN 438) of Abet Laminati
- Acoustic absorbing non woven glass fibre tissue

STD. MEASUREMENTS

- 3030 x192 mm (tongue/groove)
- 3030 x1200 mm (veneer)
- 3030 x1280 mm (HPL)

Made-to-measure on request.

PERFORATION

Standard 4.8 % continuous slits
Blade/groove: 29.2/2.8 mm

TOP LAYER

Print HPL 0.9 mm.
On request: lacquer, veneer or digital print.

CORE

Black moisture repellent MDF.
On request: standard MDF, red or black fire retardant MDF (B-s1-d0).

TEST SETUP
IN LAB:
WALLS

TOTAL THICKNESS
88 mm

f(Hz)	T1 (s)	T2 (s)	α_s
50			
63			
80			
100	11,92	7,82	0,16
125	9,12	4,99	0,34
160	10,10	4,92	0,39
200	9,86	3,77	0,61
250	9,20	2,92	0,87
315	9,25	2,54	1,06
400	9,10	2,56	1,04
500	9,19	2,95	0,85
630	10,06	3,46	0,70
800	9,81	3,92	0,57
1000	9,57	4,50	0,44
1250	9,06	4,82	0,36
1600	8,12	4,72	0,33
2000	7,25	4,57	0,30
2500	6,16	4,13	0,29
3150	5,20	3,68	0,29
4000	4,31	3,17	0,30
5000	3,40	2,49	0,39

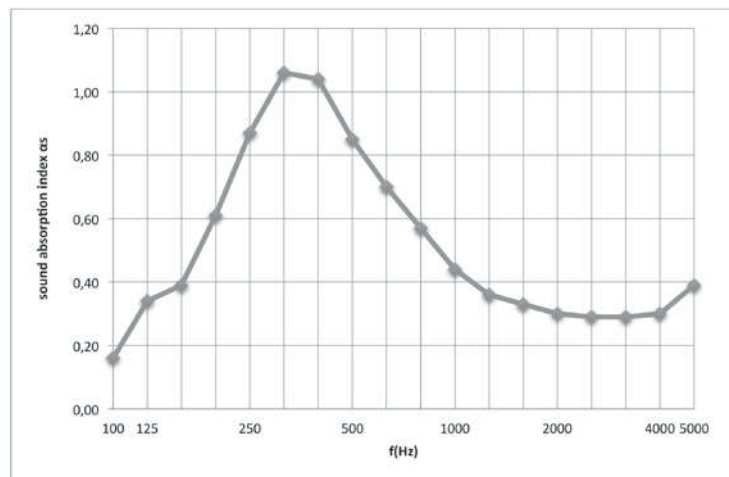

f(Hz)	α_p
125	0,30
250	0,85
500	0,85
1000	0,45
2000	0,30
4000	0,35

$\alpha_w = 0,40$ (LM)
acoustical absorption class : D

Type W 4.8 % 29.2/2.8 mm

To be mounted on a wooden frame with a thickness of 70 mm, filled with 50 mm of Rockfit 431 adapt 40 kg/m³.

TEST SETUP
IN LAB:
WALLS

TOTAL THICKNESS
38 mm

f(Hz)	T1 (s)	T2 (s)	α_s
50			
63			
80			
100	11,92	8,58	0,12
125	9,12	6,82	0,14
160	10,10	6,75	0,18
200	9,86	5,70	0,27
250	9,20	4,89	0,36
315	9,25	4,20	0,49
400	9,10	3,35	0,70
500	9,19	3,03	0,82
630	10,06	2,77	0,97
800	9,81	2,77	0,97
1000	9,57	3,10	0,81
1250	9,06	3,53	0,64
1600	8,12	3,82	0,51
2000	7,25	4,01	0,41
2500	6,16	3,87	0,35
3150	5,20	3,54	0,33
4000	4,31	3,05	0,35
5000	3,40	2,46	0,41

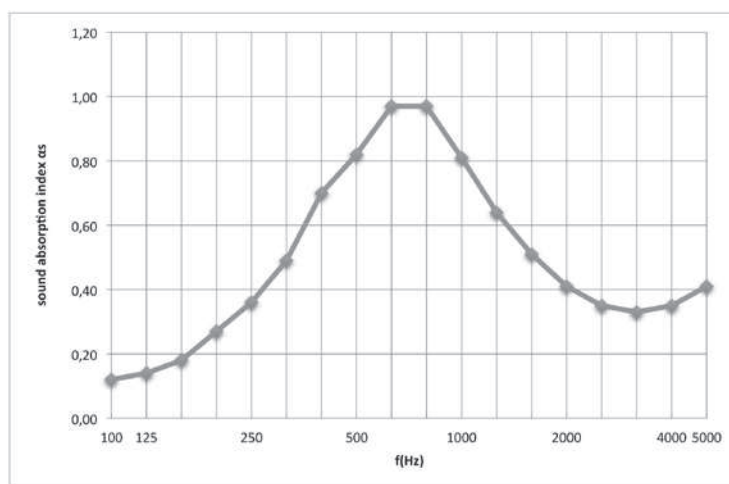

f(Hz)	α_p
125	0,15
250	0,35
500	0,85
1000	0,80
2000	0,45
4000	0,35

$\alpha_w = 0,50$ (MM)
acoustical absorption class : D

Type W 4.8 % 29.2/2.8 mm

To be mounted on a wooden frame with a thickness of 20 mm, filled with 20 mm of PRIMAWOOL 22.5 kg/m³.

TYPE W (wall)



INSTALLATION see page 50

A core of 16 mm in black MDF with acoustic absorbing non woven glass fibre tissue on the back.



Top layer and backing in Print HPL 0.9 mm.
(On request: lacquer, veneer or digital print.)

Type W 4.8 % 29.2/2.8 mm

% perfo	total thickness	α_w	NRC* <small>see page 7</small>	SAA** <small>see page 7</small>
4.8%	88 mm	0.40	0.60	0.62
	38 mm	0.50	0.60	0.61

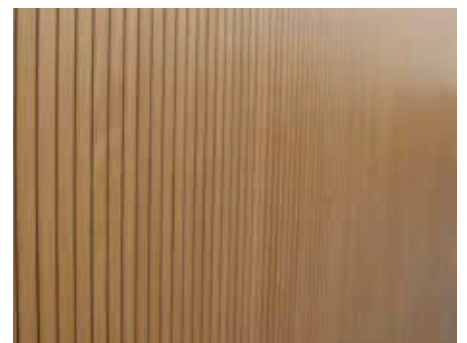

DIGITALLY PRINTED PANELS

All acoustic absorbing panels for closet doors, sliding doors as well as wall- and ceiling coverage can be delivered with digital print - Digital Print Abet Laminati or via 4-colour print with a transparent UV protective layer - allowing you to further personalize them.

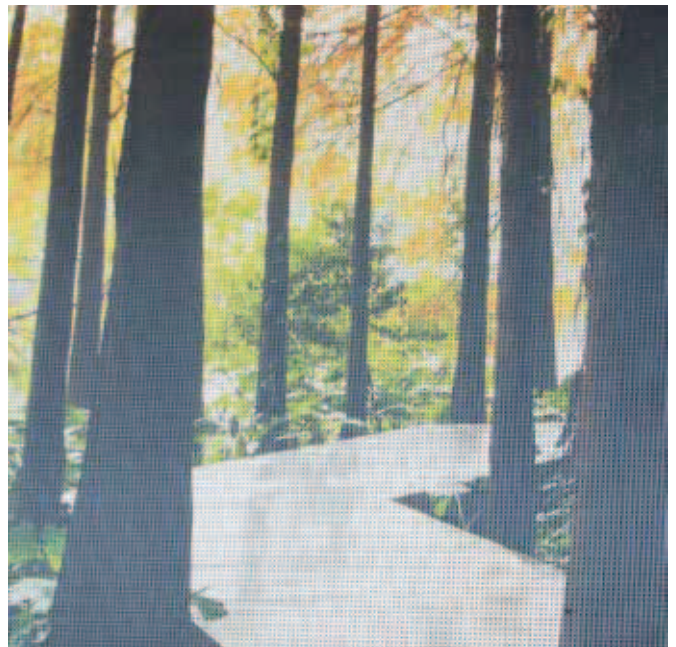
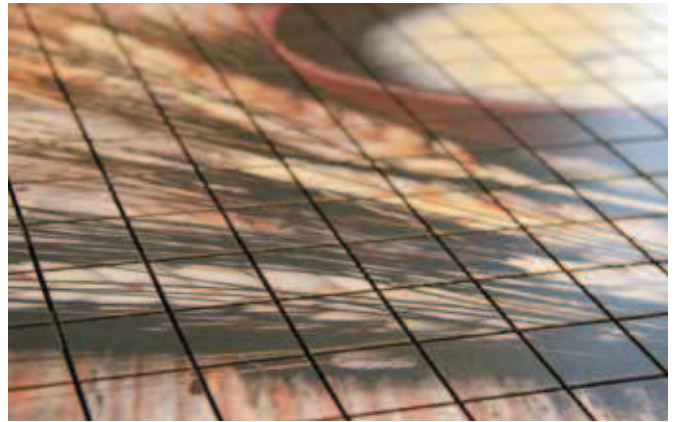
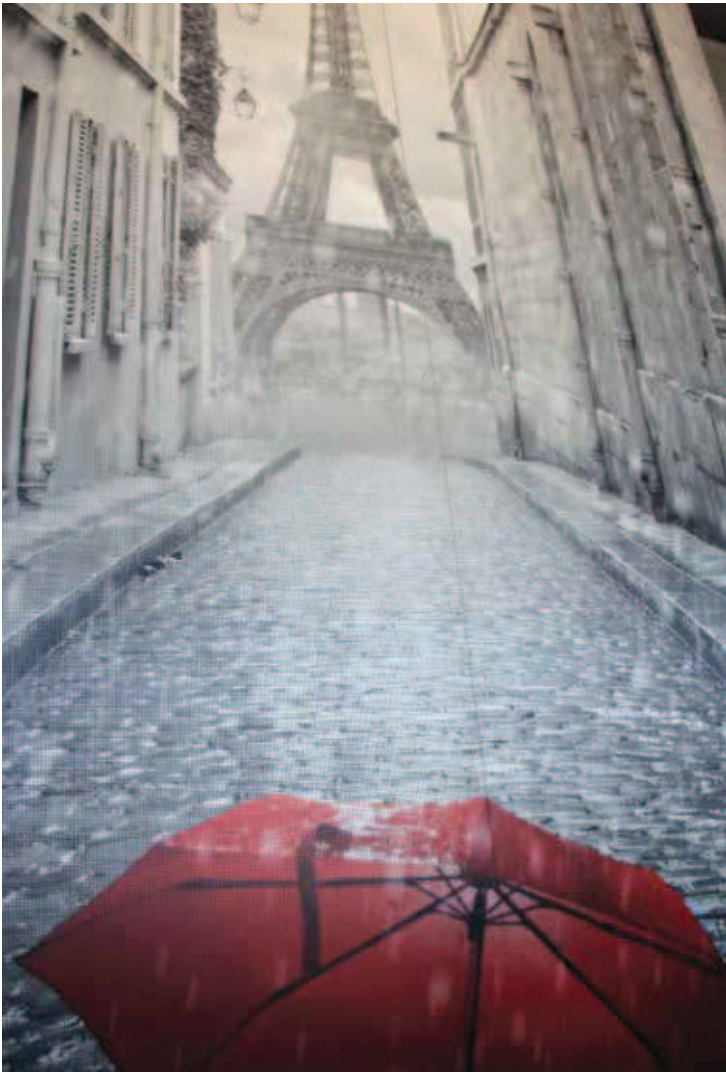

Digitally printed acoustic absorbing panels: upper left picture - door panels in type M, upper right picture - type T, middle right picture - door panels in type M, bottom picture - door panels type M integrated in a wall

MADE-TO-MEASURE CLOSET DOORS ON REQUEST

TYPE G
DEVOLDER ARCHITECTS



TYPE S
IDEWE LOUVAIN

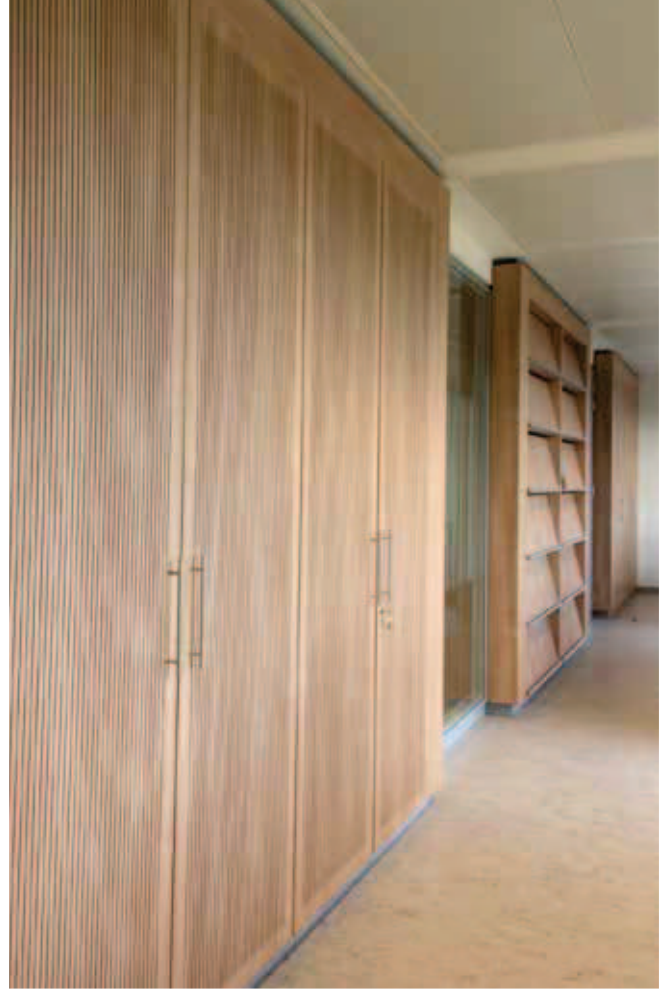

TYPE S
IDEWE LOUVAIN

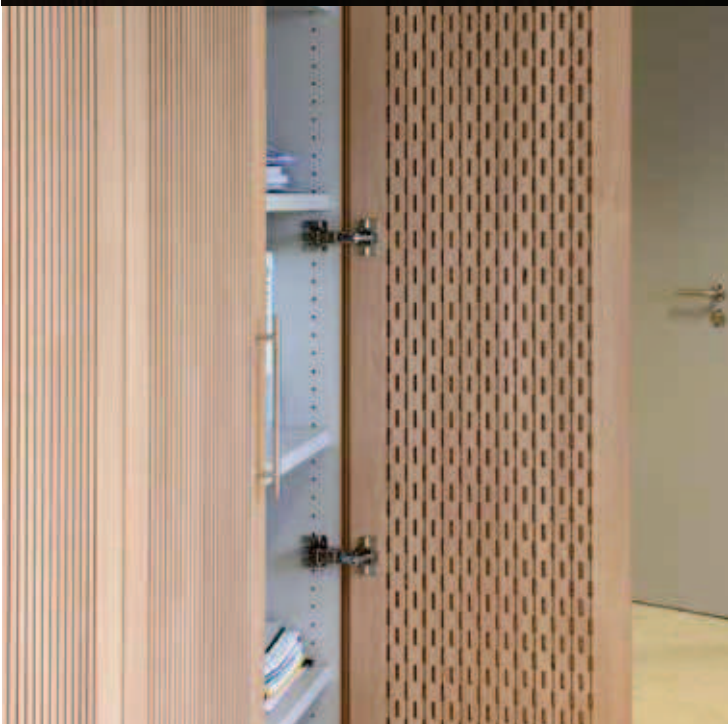

TYPE D_b
VANBECELAERE & HAUSPIE ARCHITECTS



MADE-TO-MEASURE CLOSET DOORS ON REQUEST

TYPE M with Magnetico strip
AAVO ARCHITECTS

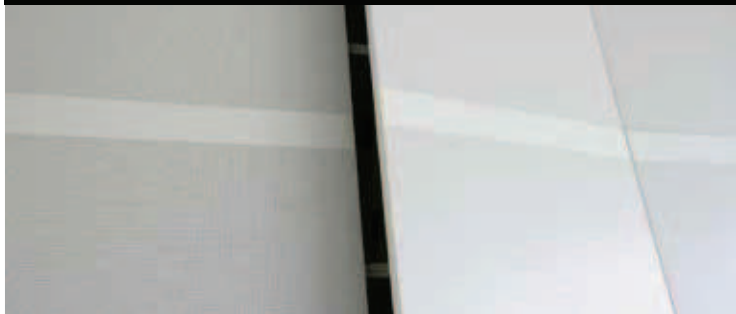

TYPE M
AAVO ARCHITECTS



TYPE Dr
VANBECELAERE & HAUSPIE ARCHITECTS



TYPE M
AAVO ARCHITECTS



TYPE M
BURO II & ARCHI+I



TYPE M
BURO II & ARCHI+I



TYPE Db
BURO II & ARCHI+I



TYPE I
ARCHITECT@WORK 2015

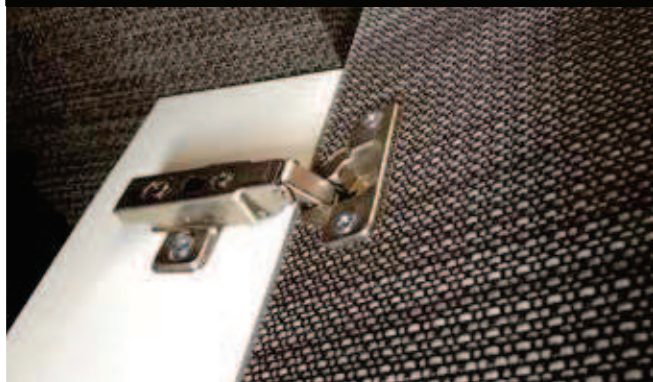

Description

- > Low density absorber
- > 100 % polyester fibre
- > 1-sided drum membrane: white
- > Colour of the polyester fibre: white
- > Applications: walls, ceilings and baffle filling

Features

- > 100 % recyclable PET
- > Inodorous
- > No emission of volatile organic compounds (VOC's) (A+-level)
- > Moisture and rot resistant
- > Non irritating for skin and eyes
- > European fire class B-s2-d0

Figures

Density	ISO 9073-1	450 gr/m ²
Thickness E0 (without load)	ISO 9073-2	22 mm (measured without packaging)
Thickness E1 (load of 50 g/50 cm ²)		21 mm (measured without packaging)
Thickness E10 (load of 500 g/50 cm ²)		13 mm (measured without packaging)
Infammability	FMVSS 302	<100 mm/min (self-extinguishing)
Dimensions role (length / width / tolerances width)		30 mm / 600 mm / -0 +2 cm
Package		36 m ² (2 separate roles of 30 lm)

Acoustical features

PRIMAWOOL®

Absorption coefficient determined by measuring a sample of PRIMAWOOL® in the reverberation room.

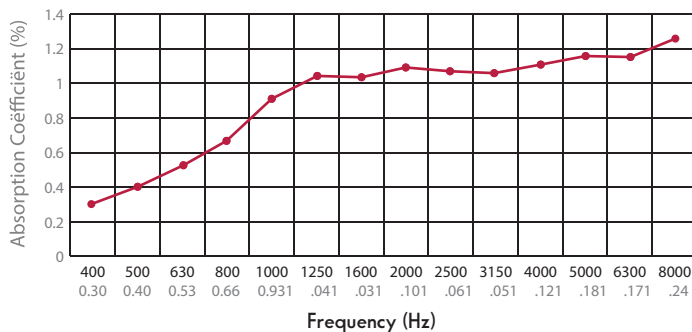

Installation of PRIMAWOOL®

Installation in a framework with vertical or horizontal wooden planks.

Framework with wooden timber

PRIMAWOOL®

Print Acoustics® panels

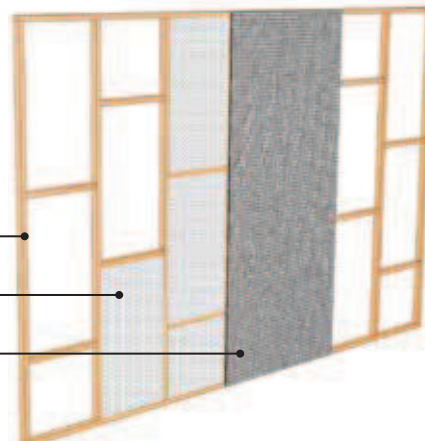

1. Print HPL

The **PRINT HPL** high pressure laminates of **Abet Laminati** consist of layers of cellulose fibrous material combined with a decorative top layer, impregnated with thermosetting resins and bonded together using a high pressure (9 Mpa = 90 kg/cm²), high temperature (150 °C) process. All top layers are manufactured according to the European norm EN 438 I/II.

These PRINT HPL laminated are also available in a **fire-retardant version M1**. The complete technical details of PRINT HPL, the available colours and textures (**more than 500 uni-colours and wood imitations**) can be requested by phone or mail at Triplaco. You can also find information on our website www.triplaco.be.



Print HPL of Abet Laminati: available in more than 500 uni-colours and wood imitations

DESCRIPTION TOP LAYERS

2. Veneer

Our acoustic absorbing panels can also be ordered with a veneer toplayer (veneer at choice: oak, beech, walnut, ash ...). Finish: transparent varnished or oil.



Fineer afwerking

3. Lacquer

According to RAL or NCS reference, finished with transparent mat lacquer.



In-house lacquering

4. Digital printing or Digital Print Abet Laminati

4-colour printing with a 2-layer transparent UV-lacquering up to 5N scratch resistance. Digital image to be provided - min. requirements 150 dpi in CMYK on scale 1/1.



Digitale printed panel type T

5. Ntgrate®

Top layer in woven vinyl. A glass fibre thread is co-extruded with a bicolore PVC-coating. A decorative fabric is woven using screenweaving machines. This is bounded to a wooden perforated panel. The back of the panel consists of acoustic absorbing non woven glass fibre tissue.



STORAGE OF FINISHED PANELS

The acoustic panels can be mounted horizontally and vertically. For conditioning, we advise to store the panels in the room at least 48 hours before mounting them. These panels are by nature and composition only to be mounted in a well conditioned room with a relative humidity between 35 and 55 % and a temperature between 14 and 30 °C.

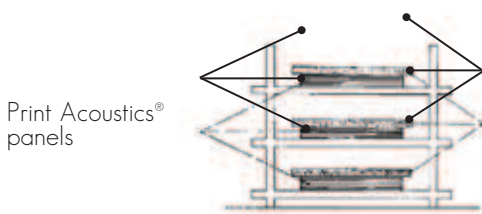

Print Acoustics® panels

Cover board of Print Acoustics® stack needs to be larger than the panels

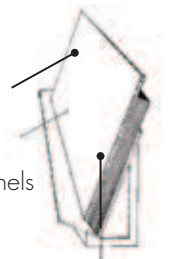

Print Acoustics® panels



Bad stacking

fig 13. Storage of finished acoustic absorbing panels

INSTALLATION TYPE S, F, G, D, Z, T, W

To be mounted on a wooden frame/ CLS (stand-alone or fixed to the wall / simple or double laths) with brads (we have adapted Senco pistols). The wooden frame is filled with sound absorbing mineral wool (e.g. Rockwool or PRIMAWOOL®).

We advise you to leave a space of 2.5 mm per meter in height and width around the wall to allow expansion.



The brads are fixed on the front of the panel with a Senco FinishPro 25XP with Print Acoustics adapted head. You can buy or rent these pneumatic pistols at Triplaco/Print Acoustics.

We advise you to use brads type Senco AX18EAA 42 mm (Code 105795). For panels type T you need to use smaller brads with ref AY18EAA 42 mm (Code 105799). Type Z can also be screwed (black screwhead diam. max. 7 mm).

Mounting: end assembly of short edges --> see page 54.

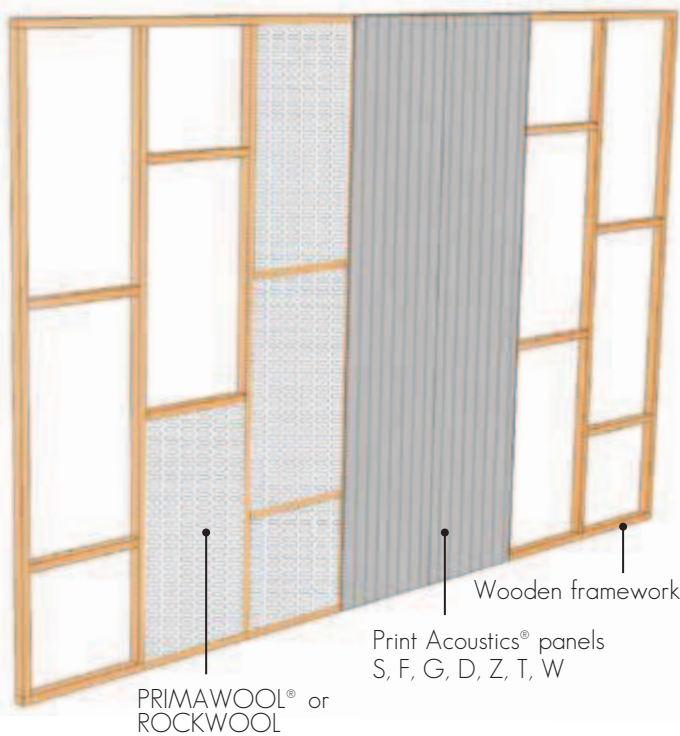

ATTENTION!

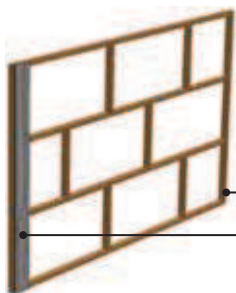

Should you use planks with tongue and groove instead of big size panels, the wooden framework has to be mounted horizontally!

Wooden framework mounted horizontally
Print Acoustics® planks with tongue and groove

TEST SETUP
IN LAB:
WALLS

TOTAL THICKNESS
88/90 mm



TEST SETUP
IN LAB:
WALLS

TOTALE THICKNESS
38/40 mm

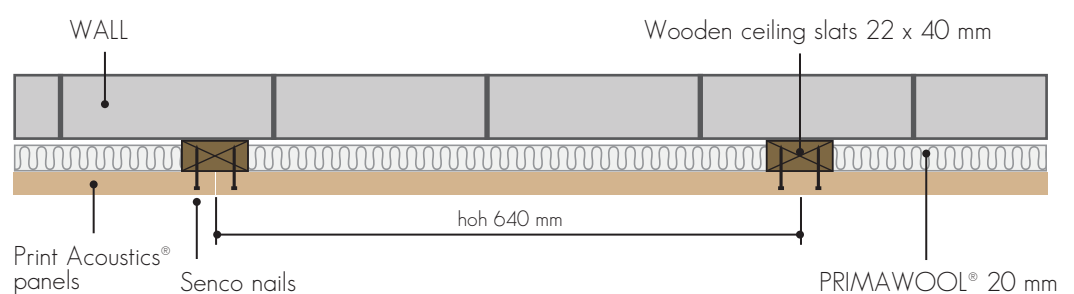
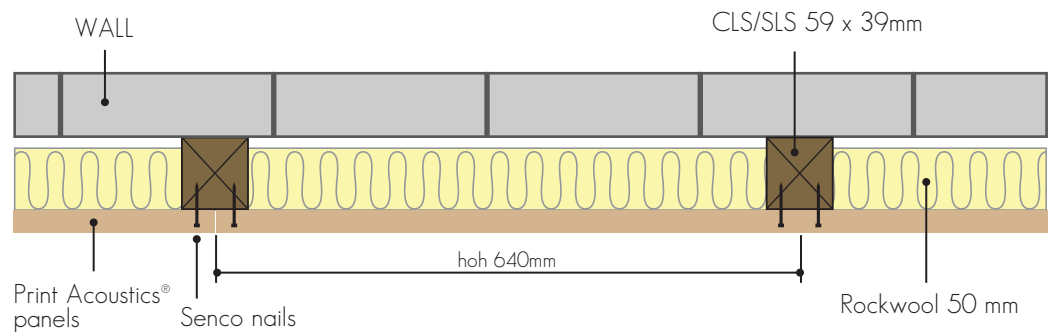

Attention! This installation advise is for panels with a width of 640 or 1280 mm. In case you use another panel width, do adapt the center to center distances accordingly!

INSTALLATION TYPE I

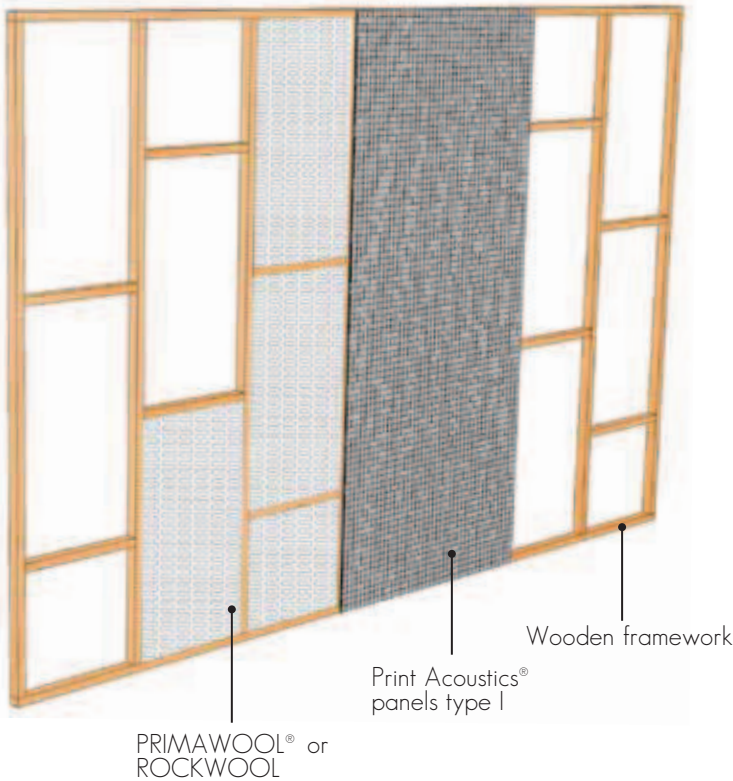

To be mounted on a wooden frame/ CLS (stand-alone or fixed to the wall / simple or double laths) with brads (we have adapted Senco pistols). The wooden frame is filled with sound absorbing mineral wool (e.g. Rockwool or PRIMAWOOL®).

We advise you to leave a space of 2.5 mm per meter in height and width around the wall to allow expansion.

You can use brads to fix the panel on the wooden frame. The brads penetrate the fabric and fix the MDF core board to the wooden frame. Do use the smallest possible brads so the fabric is not damaged.

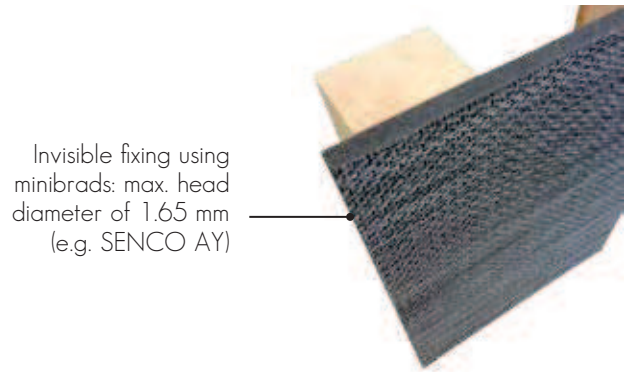

TEST SETUP
IN LAB:
WALLS

TOTAL THICKNESS
88 mm

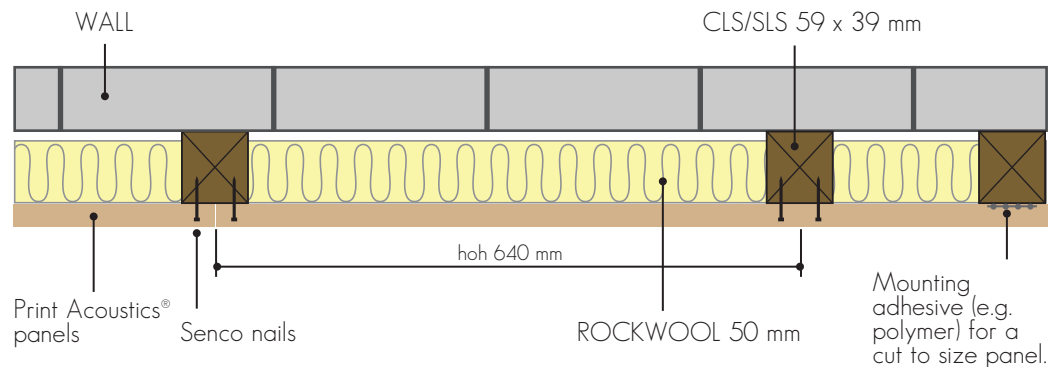

TEST SETUP
IN LAB:
WALLS

TOTAL THICKNESS
30 mm

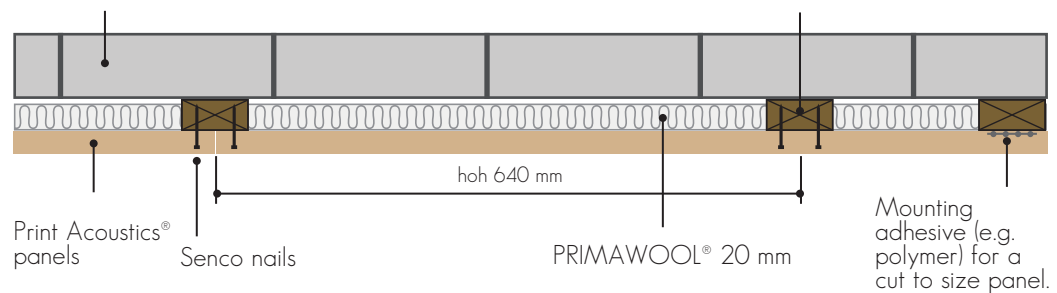

Attention! This installation advise is for panels with a width of 640 or 1280 mm. In case you use another panel width, do adapt the center to center distances accordingly!

INSTALLATION TYPE M, C, B

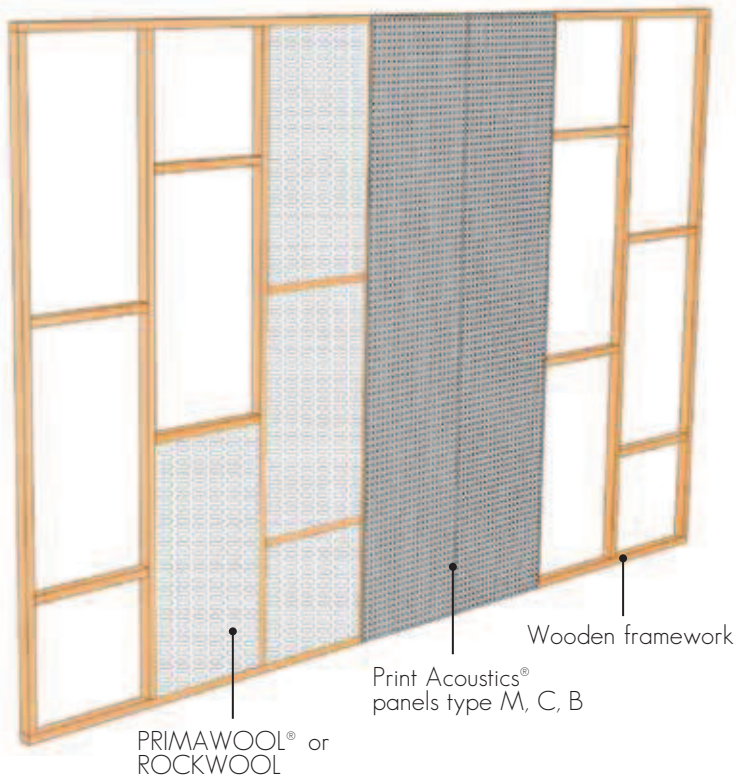

To be mounted on a wooden frame/ CLS (stand-alone or fixed to the wall / simple or double laths) with invisible 45° splice joints. The wooden frame is filled with sound absorbing mineral wool (e.g. Rockwool or PRIMAWOOL®).

We advise you to leave a space of 2.5 mm per meter in height and width around the wall to allow expansion.

The invisible splice joints are screwed on the back of the panels. The acoustic absorbing panels are mounted on the other half of the splice joint wall side.

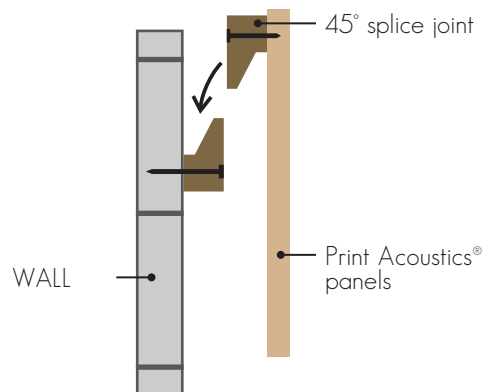

TEST SETUP
IN LAB:
WALLS

TOTAL THICKNESS
88/90 mm

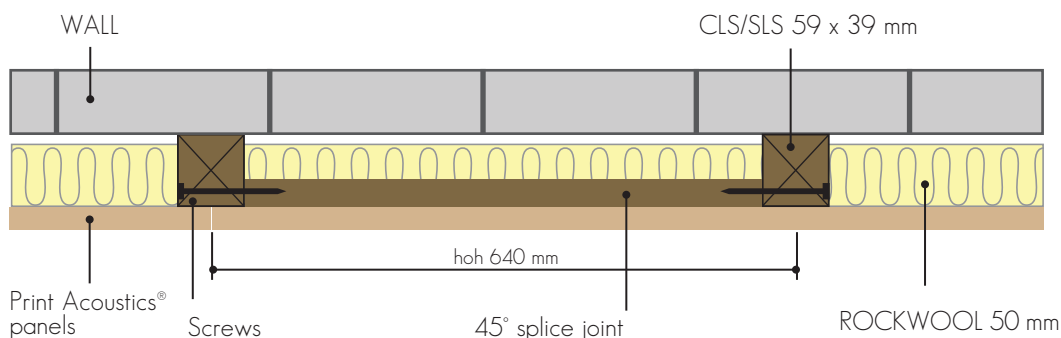

TEST SETUP
IN LAB:
WALLS

TOTAL THICKNESS
38/40 mm

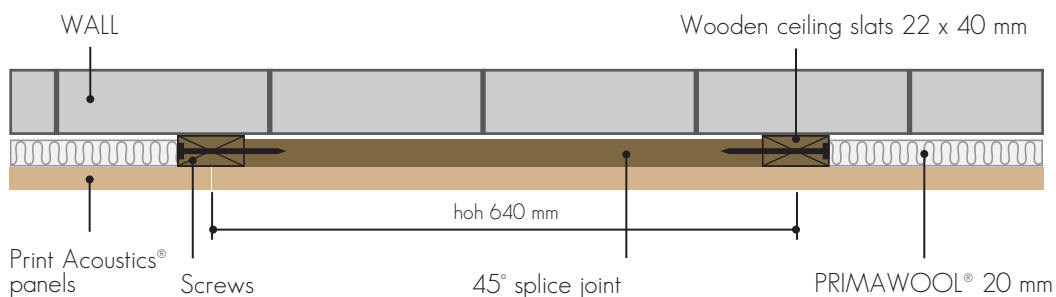

Attention! This installation advise is for panels with a width of 640 or 1280 mm. In case you use another panel width, do adapt the center to center distances accordingly!

FINISHING POSSIBILITIES PRINT ACOUSTICS® PANELS MITRE CUTTING OF EXTERIOR ANGLES

* You are responsible for the mitre cutting of the panels.

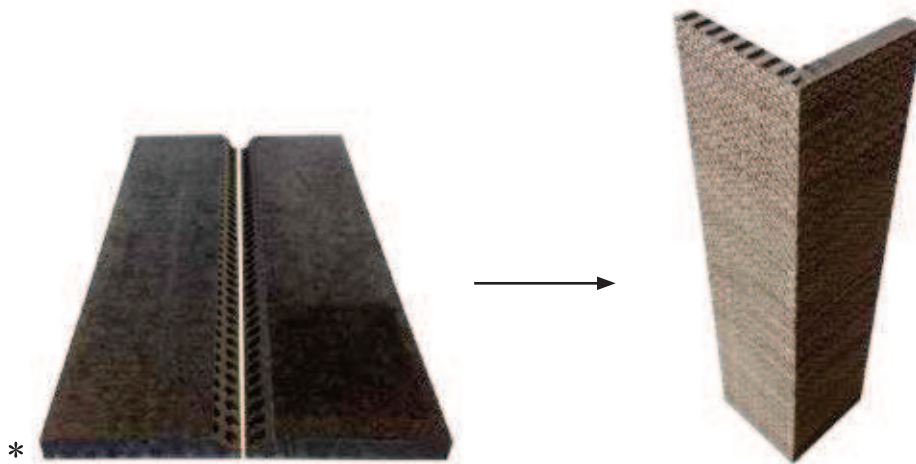

Example of mitre cutting of exterior angles - TYPE I

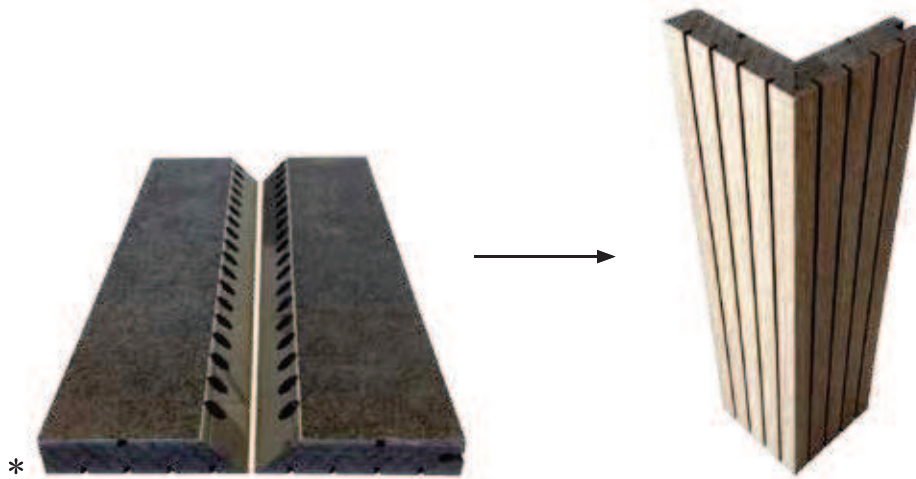

Example of mitre cutting of exterior angles - TYPE G

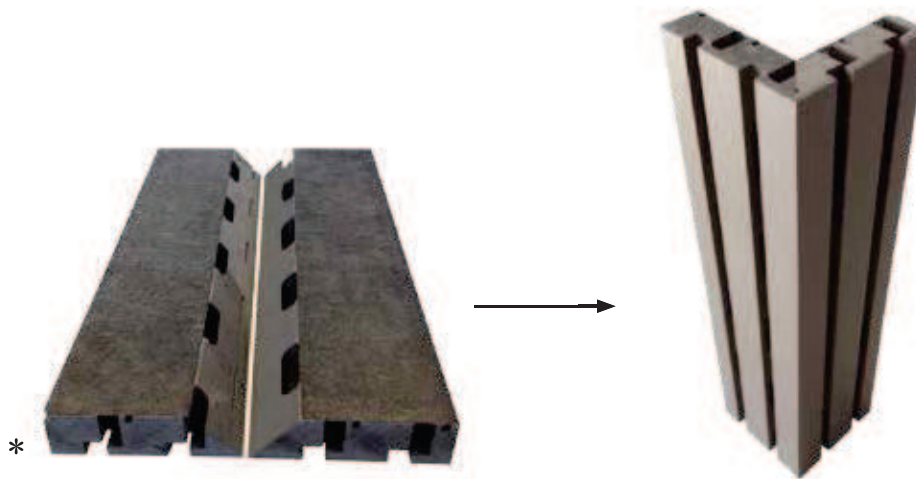

Example of mitre cutting of exterior angles - TYPE Z

FINISHING POSSIBILITIES PRINT ACOUSTICS® PANELS

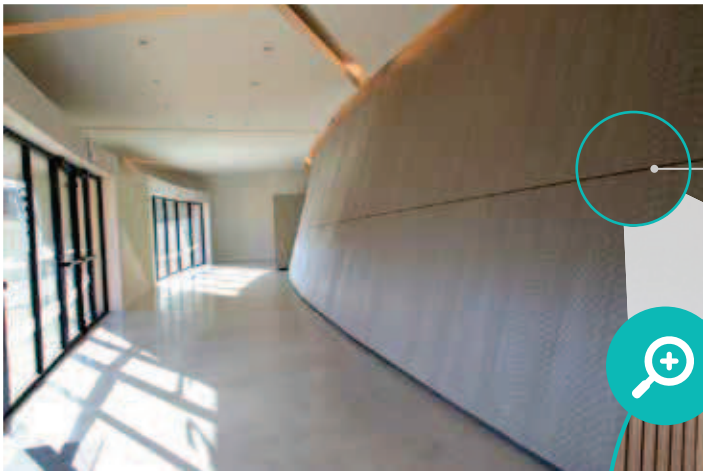

When installing grooved panels you should include a shadow gap.

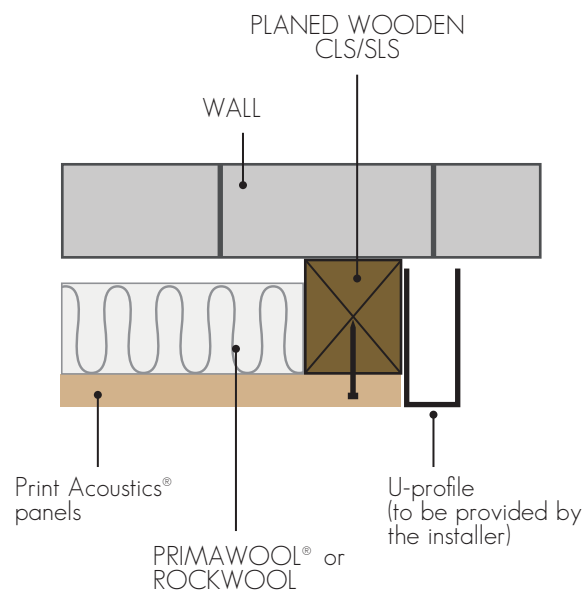
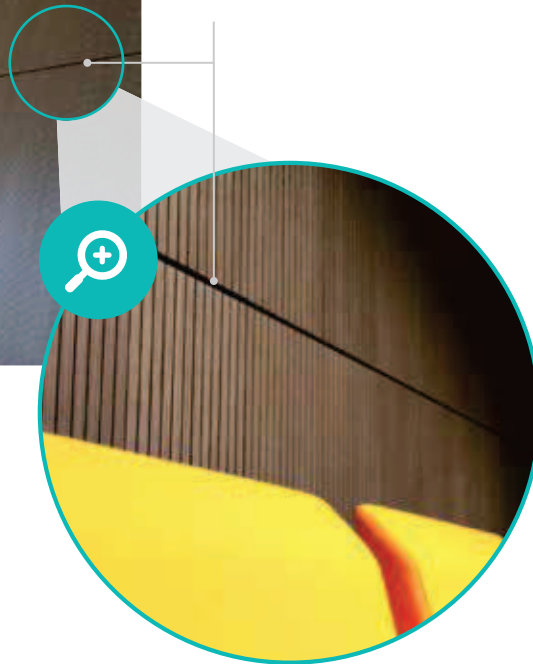

Example of finishing border with aluminium U-profile - TYPE I

FINISHING POSSIBILITIES PRINT ACOUSTICS® PANELS

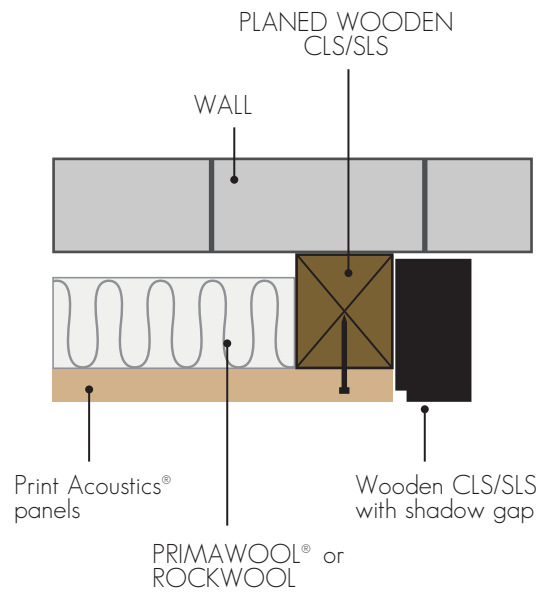

Example of finishing border with wooden CLS/SLS - TYPE I

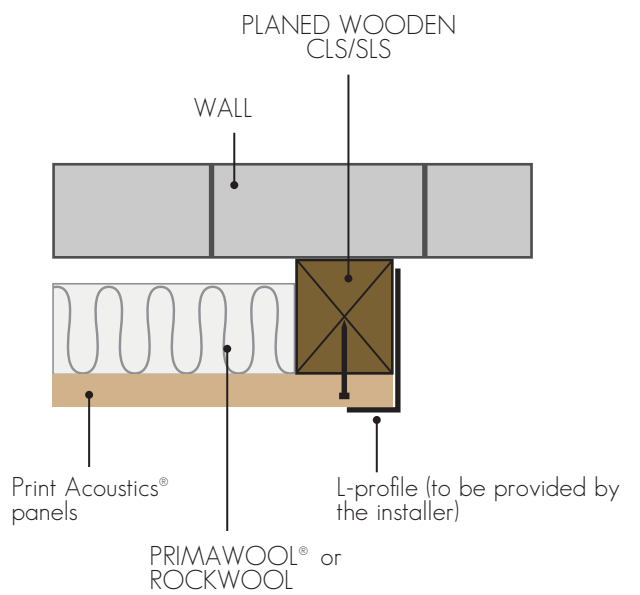
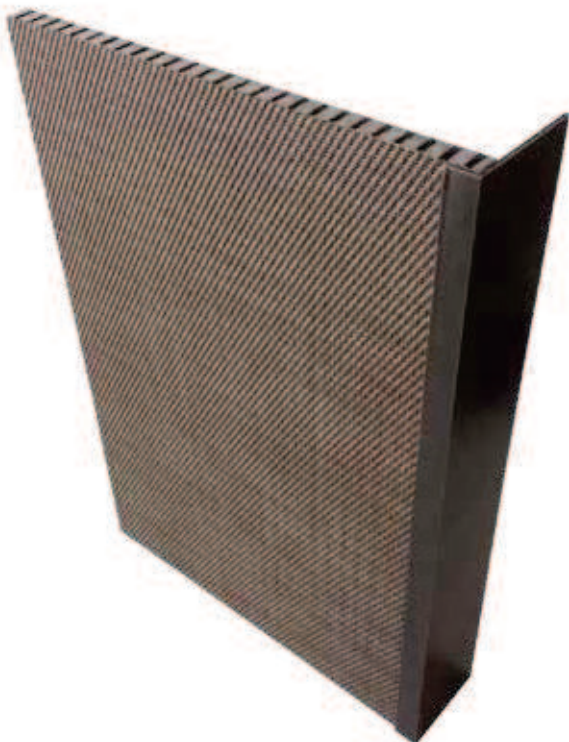

Example of finishing border with aluminium L-profile - TYPE I

FINISHING POSSIBILITIES PRINT ACOUSTICS® PANELS

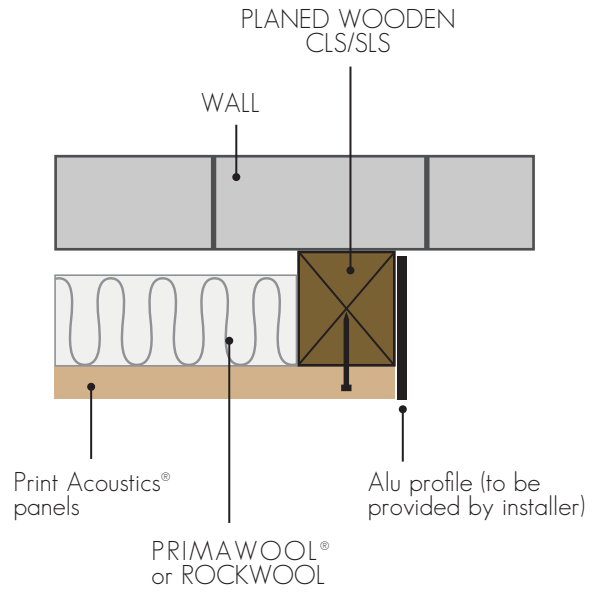

Example of finishing border with aluminium profile - TYPE I

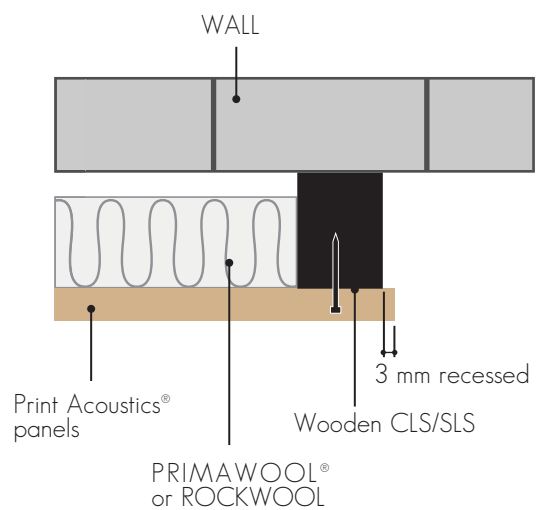
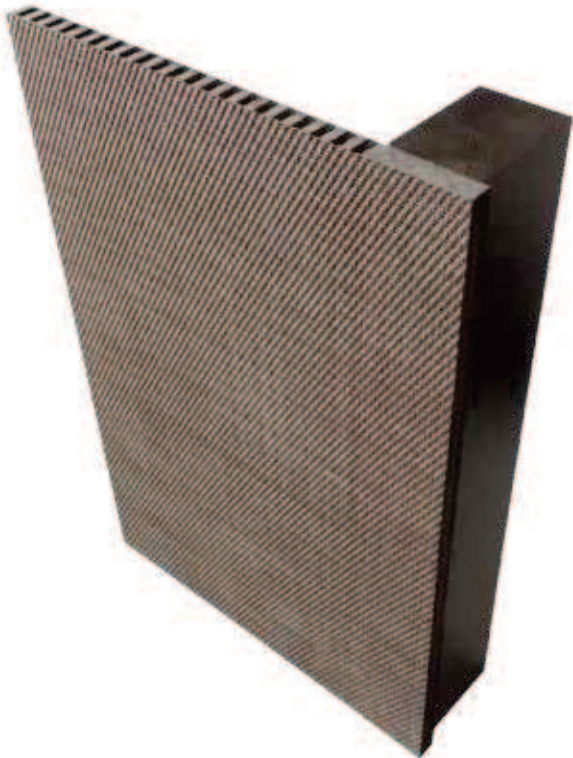

Example of finishing border with recessed wooden CLS/SLS - TYPE I

FINISHING POSSIBILITIES PRINT ACOUSTICS® PANELS

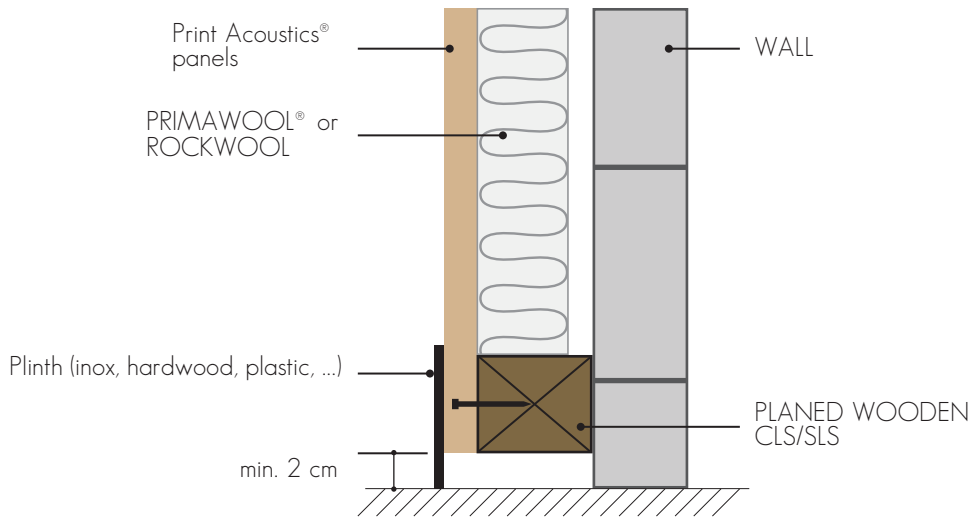

Example of finishing with plinth - version 1

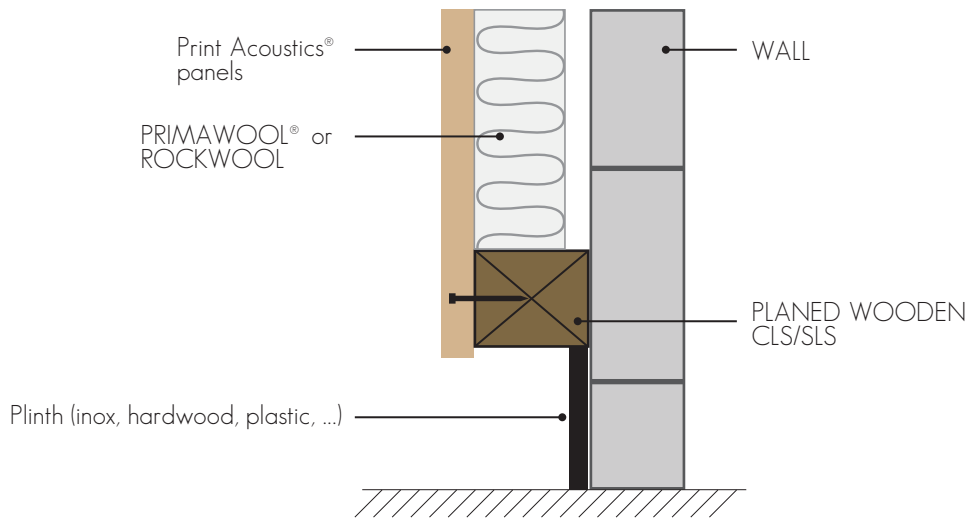

Example of finishing with plinth - version 2

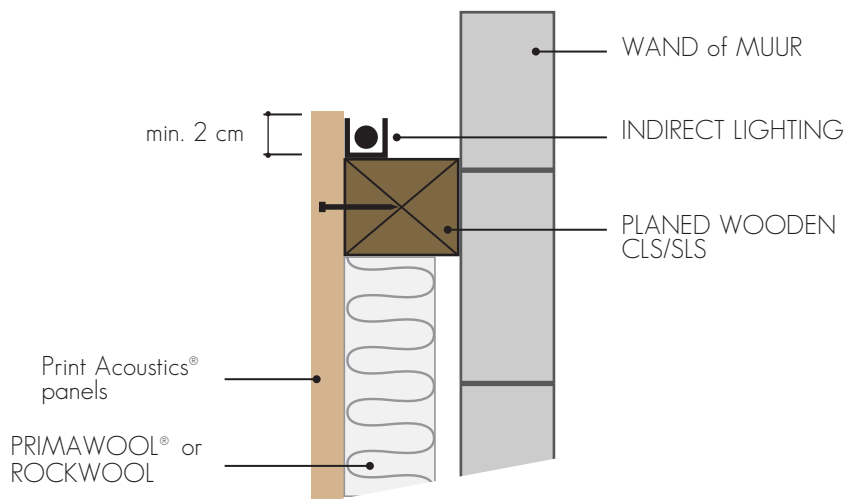

Example of finishing with indirect LED lighting on top

ADVISED REVERBERATION TIMES (IN SECONDS)

BUSINESS

Office	0.5 - 0.8 (building regulation: max 0,8)
Callcenter	0.5 - 0.8
Meeting room	0.6 - 0.8 (building regulation: max 0,8)
Reception hall	0.6 - 1.0 (building regulation: max 1,0)
Waiting room	0.7 - 1.0 (building regulation: max 1,0)
Doctor's practice	0.6 - 0.8 (building regulation: max 0,8)
Doctor's office	0.5 - 0.6 (building regulation: max 0,6)

SPORTS FACILITIES

Swimming pool	1.2 - 1.5 (building regulation: max 1,5)
Sports hall	1.2 - 1.5 (building regulation: max 1,5)

EDUCATION

Classroom (technical)	0.5 - 0.8 (building regulation: max 0,8)
Classroom (practical)	0.6 - 0.8 (building regulation: max 0,8)
Nursery	0.5 - 0.8 (building regulation: max 0,8)
Sports area	1.2 - 1.5 (building regulation: max 1,5)

HORECA

Restaurant	0.5 - 0.7
Cosy Pub	0.5 - 0.7
Café with musique	0.8 - 1.0

MUSIC STUDIOS

Recording studio	0.2 - 0.4
Repetition room	0.7 - 0.9

INDUSTRIAL BUILDINGS

Distribution centre	0.7 - 1.0
Warehouse	0.7 - 1.0
Production	0.7 - 1.0

DOMESTIC

Living room	0.4 - 0.7
Home theatre	0.3 - 0.5



Helmholtz absorption is one of the **most effective ways for acoustical correction of reverberation caused by human voice in a room**. Our panels are mostly mounted as wall cladding, perpendicular to the propulsed sound wave, direct absorption close to source..



Our panels are standard equipped with a core in **moisture repellent** black MDF. This gives a refined and timeless design to our products and is far better than a core in standard brown MDF. The toplayer is **easy to clean** (with moisture towel and household cleaning detergent).



Custom-made panels.

Closets, sliding doors,... can be manufactured on demand, based on your plans.



All products are **scratch- and impact resistance**.



Wide range of decorative toplayers.

The panels can be standard delivered with Abet Laminati Print HPL layer, but also with veneer, lacquer, digital print or Ntgrate® woven vinyl.

Shhhhhhh...

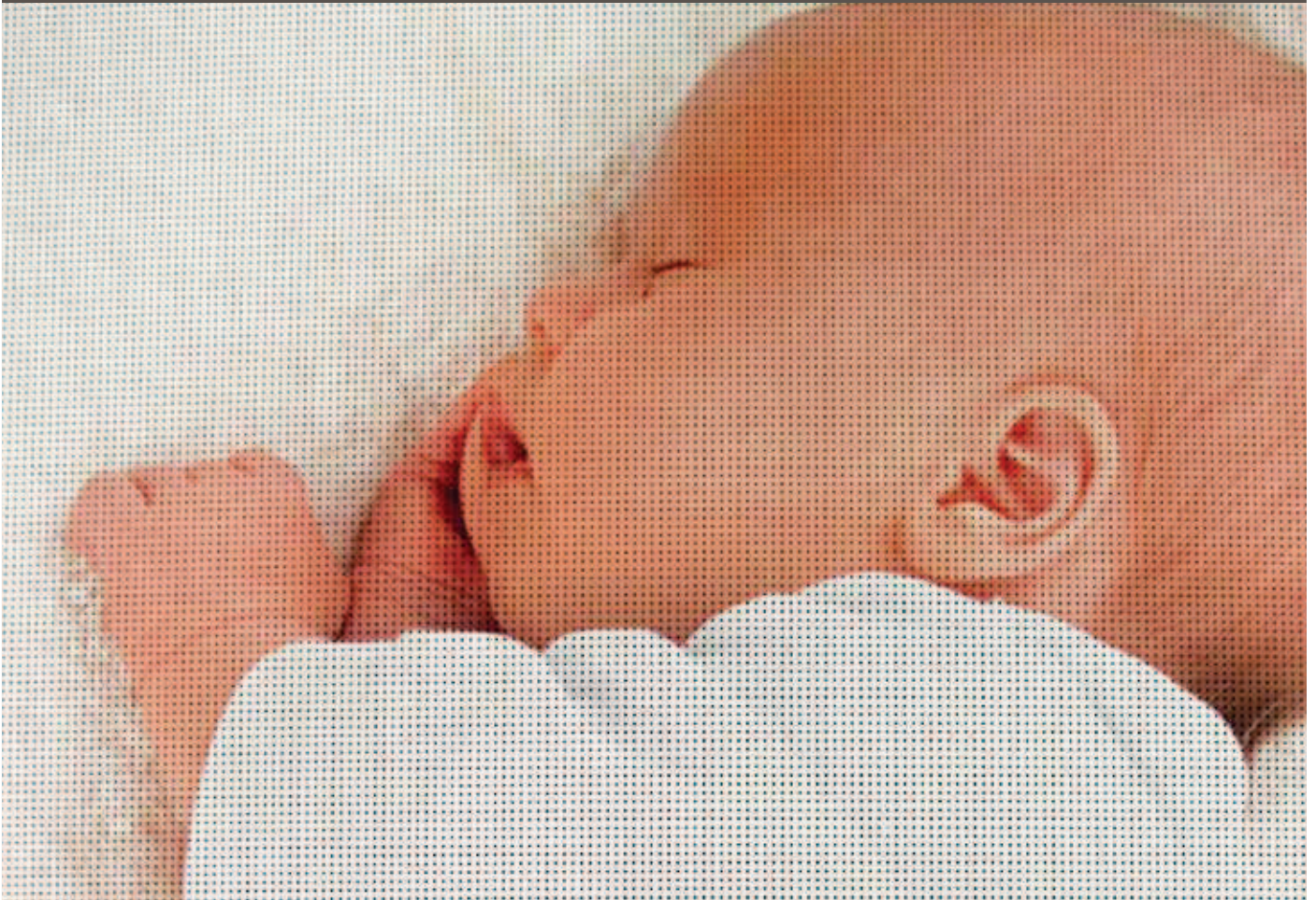

Your dealer:



Our partners:

