

Reynobond[®]
Architecture

Reynobond[®] Aluminum
Composite Material





Versatile Solutions for Any Project.

Whether you're an architect, engineer, designer, fabricator, installer or contractor, each new project presents a fresh set of challenges. And your ability to meet those unique challenges is how your clients measure your work. That's why we are committed to finding new ways to help you achieve your vision with the beauty, affordability and ease of installation of Reynobond®.

Discover stylish and functional cladding solutions for both interior and exterior applications with our innovative products, including Reynobond Aluminum Composite Material, Reynobond Natural Metal Composite Material, Reynobond with KEVLAR® hurricane impact panels, Reynobond with EcoClean™, Reynobond Design Line, Anodized Reynobond and Reynolux®. And each of our product offerings provide the durability to ensure your project will look pristine for years to come—with minimal maintenance.

We're constantly extending our range of support services, such as comprehensive CAD drawings, custom design solutions, on-site consultation and more. Discover how we can help expand your design possibilities with many versatile solutions for any project—from inspiration to implementation.

Chihuahua's Businessmen Foundation (FECHAC) Regional Office
Ciudad Juárez, Chihuahua, Mexico



Reynobond® – Make a Statement.



Exceptionally Flat

The strong, rigid construction of Reynobond® composite material consists of a polyethylene or fire-retardant compound core between two sheets of aluminum, brushed aluminum, zinc or copper. This creates a flat surface that virtually eliminates dimpling, buckling and oil canning—even retaining its flatness after folding!

Daringly Formable

Achieve small-radius curves, reverse curves, angles, tessellated geometric shapes and other contours you never thought possible. Reynobond is easily routed, drilled, punched, cut, bent, curved and formed.

Distinctively Colorful

Get outstanding color and gloss retention in a virtually limitless range of hues. Standard and custom finishes are available, including anodic colors and even nature-inspired Design Line advanced polymer finishes. Continuous coil application ensures consistent, long-lasting color.

Surprisingly Light

The light weight of Reynobond allows a wide variety of design options, and installation is quick and easy. For renovation work, cladding can often be installed with little or no alteration to existing structural elements.



United Therapeutics Corporation
Silver Spring, Maryland



Easily Integrated

Reynobond integrates easily with the curtain wall provided by most manufacturers. The result is a seamless look for a building's façade – with the added design characteristics that only Reynobond can offer.

Beautiful Accents

Reynobond's family of Natural Metal products allows every component of the structure to become a design element. Reynobond's strength, weight and formability allow you to achieve designs that are not feasible with other materials.

A Perfect Match

Reynolux® Aluminum Wall Panels and Flashing Sheets are the perfect complement to our family of Reynobond Aluminum Composite Material products. The ability to combine these high-quality products in pre-matched or custom colors gives you a number of distinct design advantages.

Safe & Compliant

Reynobond is designed and tested to meet safety and environmental building codes around the world. It is available with either a polyethylene (PE) core or a fire-resistant (FR) core material, both of which provide the flatness and formability required for your most demanding applications.



Reynobond® Natural Metals – Strikingly Beautiful. Naturally Bold.

Get all the functional benefits of Reynobond® along with the aesthetic appeal of nature with our Reynobond Natural Metals. Our Brushed Aluminum, Zinc, and Copper composite panels give you bold options for interior and exterior walls and accents. And since it's Reynobond, you get the flatness and formability you demand that may not be possible with other building products.

Reynobond Natural Brushed Aluminum

Reynobond Natural Brushed Aluminum combines the natural beauty of brushed aluminum with a high-performance protective coating to meet your consistency and durability requirements. It's ideal for exterior architectural wall panel applications, and is fingerprint resistant, making it perfectly suited for interior applications.

Reynobond Zinc Composite Material

Made with a metal-zinc alloy that's stronger than common zinc, ZCM weathers naturally with no coatings required – scratches and imperfections melt away over time. It greatly expands the number of architectural applications where zinc façades and accents can be used on your building's envelope.

Reynobond Copper

Created specifically for use as an interior or exterior wall accent panel, Reynobond Copper blends the natural beauty of copper with the flatness and formability of composite panels. With a natural green patina that develops over time, Reynobond Copper lends a classic look to any architectural project.

University Hospitals Seidman Cancer Center
Cleveland, Ohio

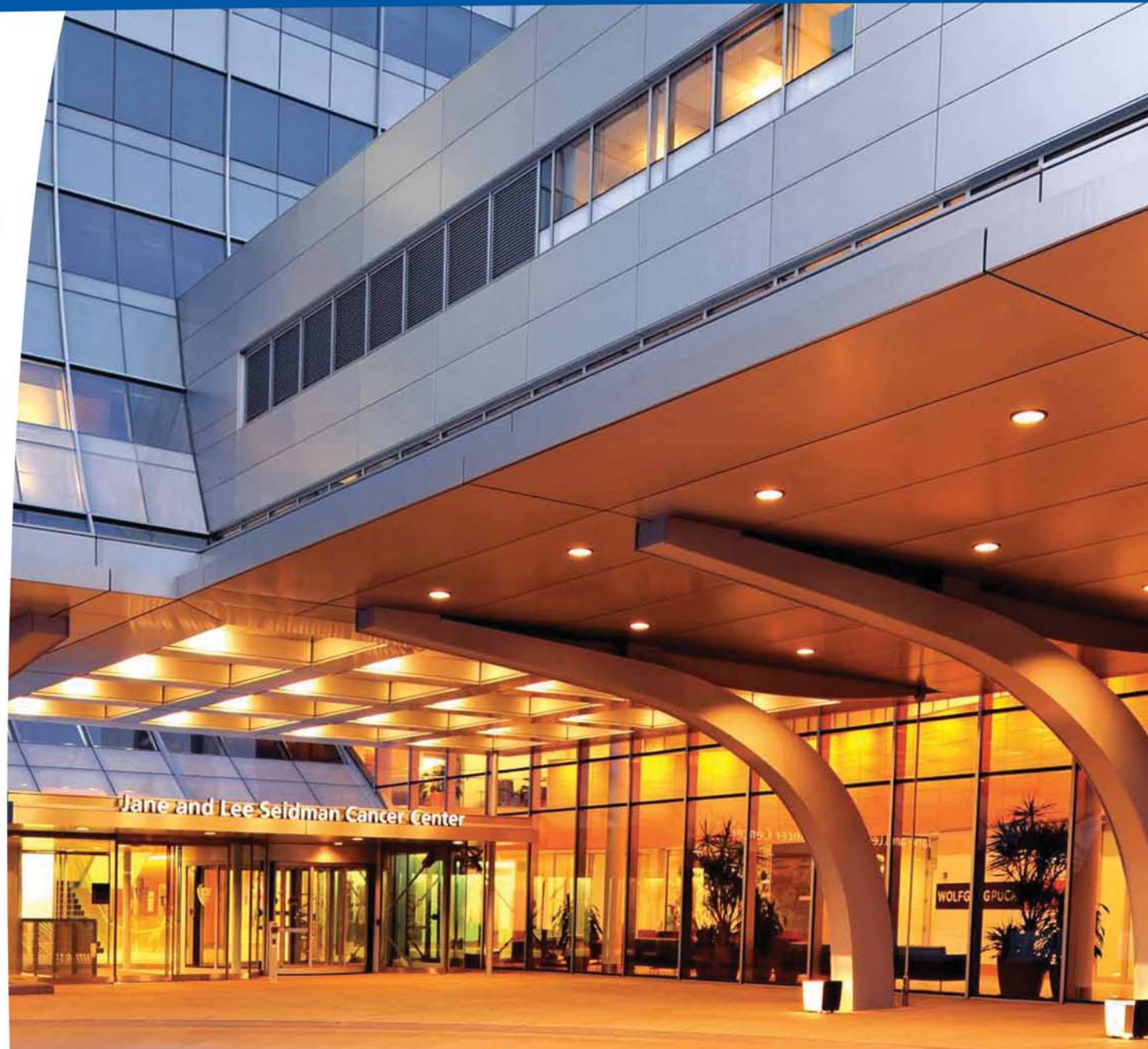

Innovation Meets Functionality.

Reynobond® with KEVLAR® – Lightweight. Flexible. Impact resistant.

When you combine the benefits of Reynobond® with the impact-resistant strength of KEVLAR® you get the first and only aluminum composite panel system that eliminates the need for protective heavy backer materials such as plywood, steel or concrete behind the panel system. DuPont™ KEVLAR® is five times stronger than steel on an equal weight basis, making Reynobond with KEVLAR® the only standalone aluminum composite material that meets the stringent requirements of the Miami-Dade County Building Code. It's the only light, flexible aluminum composite panel that can withstand hurricane-propelled debris and similar types of impact.



Reynobond with EcoClean™ – Innovation for a greener, cleaner planet.

EcoClean™ is an advanced titanium dioxide coating that, when applied to Reynobond, reacts with NOx (nitrogen oxide), the primary component of smog, breaking it down into harmless nitrates. This proprietary process enables the slightest bit of moisture, such as light rain or morning dew, to wash away organic particles. EcoClean™ is a photocatalytic coating that also destroys organic pollutants in reaction with UV light. Architects and building owners who are looking for positive ways to impact the environment and keep building surfaces looking fresh over time will find Reynobond with EcoClean™ the smart, innovative way to combine form with function.



Reynobond Face Fastened Solution – Utility meets style.

Now you can get all the durability, versatility and flexibility of Reynobond in an economical face fastened solution. It's perfect for new and retrofit projects less than 40 feet (three stories) high. Since it can withstand extreme temperatures and humidity, there are no geographic limitations on where Reynobond Face Fastened Solution can be used. And it's 100% recyclable.



Reynobond Architectural Finishes – Variety and Durability.

Colorweld® 500 – High-performance color that lasts.

Reynobond Aluminum Composite Material is protected and colored with enhanced, high-performance Colorweld® 500 coatings, the premier architectural coatings for metal. These finishes feature 70% Kynar 500®/Hylar 5000® polyvinylidene fluoride (PVDF) resins with Fluoropolymer technology, coil coated to ensure the highest color uniformity and quality. They provide excellent flexibility and film adhesion for forming and offer superior resistance to humidity, impact, salt spray, pollution and abrasion. With a 30-year finish warranty, Colorweld 500 coatings exhibit outstanding color and gloss retention and improved hardness and durability.



Reynobond Design Line – Nature. Now available in aluminum.

Now you can enjoy the aesthetic appeal of wood, mineral, granite, stone and natural patina with the durability, flexibility and strength of Reynobond in our nature-inspired Design Line finishes. These striking advanced polymer finishes create endless design possibilities, for both interior and exterior applications. All Design Line coatings are exterior grade and are backed by a 20-year finish warranty.



Anodized Reynobond – Beauty that's much more than skin deep.

Discover a harder, smoother surface with superior resistance to abrasion and corrosion with our Anodized Reynobond. This environmentally friendly product features an inorganic anodic coating that fully integrates with the aluminum for total bonding and is unaffected by ultraviolet rays. Anodized Reynobond is available in a variety of standard and custom colors.



General Technical Data

Reynobond® ACM Technical Overview

Property	Units	RB120PE-3 mm	RB160PE-4 mm	RB240PE-6 mm	RB160FR-4 mm	Reynobond® with KEVLAR®
Thickness	Inches mm	0.118 3.0	0.157 4.0	0.236 6.0	0.157 4.0	0.157 4.0
Weight	lb/ft² Kg/m²	0.94 4.59	1.12 5.47	1.51 7.37	1.53 7.48	1.10 5.37
Min. Bond Strength ASTM D1781	in-lb/in	25	25	25	22.5	25
	Nm/m	178	178	178	100	178
Flatwise Shear ASTM D1002	lb/in²	1,297	1,221	2,055	928	735
	Mpa	8.94	8.42	14.17	6.4	5.07
Allowable Bending Stress (1)	lb/in² Mpa	11,500 79.3	11,500 79.3	11,500 79.3	11,500 79.3	11,500 79.3
Coefficient of Expansion ASTM E228	in/in/F mm/m/C	1.31x10 ⁻⁵ 2.36x10 ⁻⁵	1.31x10 ⁻⁵ 2.36x10 ⁻⁵	1.31x10 ⁻⁵ 2.36x10 ⁻⁵	1.31x10 ⁻⁵ 2.36x10 ⁻⁵	1.31x10 ⁻⁵ 2.36x10 ⁻⁵
Stiffness (EI)	lb in³/in Mpa cm³/m	807 9.1x10 ⁵	1,140 12.8x10 ⁵	1,896 21.4x10 ⁵	1,262 14.3x10 ⁵	776 8.7x10 ⁵
Flexural Modulus Aged per ASTM C393 (2)	lb/in² Mpa	8.3x10 ⁶ 57.2x10 ³	6.0x10 ⁶ 41.4x10 ³	4.0x10 ⁶ 27.6x10 ³	6.7x10 ⁶ 46.2x10 ³	4.08x10 ⁶ 28.2x10 ³
Moment of Inertia	in⁴/in cm⁴/m	0.97x10 ⁻⁴ 0.159	1.89x10 ⁻⁴ 0.310	4.58x10 ⁻⁴ 0.751	1.89x10 ⁻⁴ 0.310	1.89x10 ⁻⁴ 0.310
Section Modulus	in³/in cm³/m	1.65x10 ⁻⁸ 1.065	2.41x10 ⁻⁸ 1.555	3.88x10 ⁻⁸ 2.503	2.41x10 ⁻⁸ 1.555	2.41x10 ⁻⁸ 1.555
Tensile Yield ASTM D638	lb/in² Mpa	8,300 57.23	6,405 44.16	5,314 36.64	6,367 43.90	15,700 108.25
Flatwise Tensile ASTM C297	lb/in² Mpa	1,483 10.22	1,371 9.45	1,099 7.58	961 6.62	513 3.53

(1) Allowable stress may be increased by 33% for wind load.

(2) Reynobond with KEVLAR® flex modulus fabric side up.

Information contained herein or related hereto is intended only for evaluation by technically skilled persons, with any use thereof to be at their independent discretion and risk. Such information is believed to be reliable, but Alcoa Architectural Products ("Alcoa") shall have no responsibility or liability for results obtained or damages resulting from such use. Alcoa grants no license under, and shall have no responsibility or liability for infringement of, any patent or other proprietary right. Nothing in this document should be construed as a warranty or guarantee by Alcoa, and the only applicable warranties will be those set forth in Alcoa acknowledgement or in any printed warranty documents issued by Alcoa. The foregoing may be waived or modified only in writing by an Alcoa officer.

For a complete technical overview of all Reynobond products, visit reynobond.com.

Paint Finish Quick Specification Reference

	CW 500/CW 500XL	DURAGLOSS® 5000	DURAGLOSS® 3000	CORAFLO®	FLUOROBRITE™	COLORWELD® 100
Warranty	30 yrs.	15 yrs.	10 yrs.	20 yrs.	5 yrs.	5 yrs.
Resin Type	70% PVDF	Modified Polyester	Modified Polyester	FEVE	FEVE	Polyester
UV Performance	*****	****	***	***	**	*
Gloss Range	20% – 35%	25% – 35%	20% – 80%	20% – 35%	20% – 80%	20% – 80%
Colors	Opacques Metallics	Opacques Metallics	Opacques Metallics Bright Colors	Opacques Metallics	Bright Colors	Opacques Metallics Bright Colors
Economics	\$\$\$\$	\$\$\$	\$\$	\$\$\$\$	\$\$\$\$	\$

Product Availability

	Thickness	Standard Widths**	Standard Lengths*
RB120PE-3 mm	3 mm (0.118")	Consult for program widths including: 1000 mm (39.37") 1220 mm (48") 1270 mm (50") 1295 mm (51") 1524 mm (60") 1575 mm (62")	1220 mm (48") to 6172 mm (20' 3")
RB160PE-4 mm	4 mm (0.157")	1270 mm (50") 1575 mm (62")	1220 mm (48") to 6172 mm (20' 3")
RB240PE-6 mm	6 mm (0.236")	1270 mm (50") 1575 mm (62")	1220 mm (48") to 6172 mm (20' 3")
RB160FR-4 mm	4 mm (0.157")	1270 mm (50") 1575 mm (62")	1220 mm (48") to 6172 mm (20' 3")
Reynobond with KEVLAR®	4 mm (0.157")	1270 mm (50") 1575 mm (62")	1220 mm (48") to 6172 mm (20' 3")

*Consult for standard lengths. **Consult for color & finish availability.

Building Code Recognition

Southwest Research Institute Design Listing	No. 01.25000.02.197
IBC 2009	MEA 75-91-M, MEA 390-99-M
ICC-ES AC25 Report	Pending
State of Wisconsin Approval	No. 990033-I
Miami-Dade N.O.A.*	No. 09-0625.01, No. 10-1118.05, No. 11-1102.01
Florida Product Approval	FL10220 Validated
Canadian Fire Test	CAN S101
Canadian Fire Test	CAN S102
Canadian Fire Test	CAN S134

Chicago • Canada • United Kingdom • Singapore
Australia • New Zealand • Malaysia • France
Germany • China • Hong Kong • Poland • Israel

*The Miami-Dade County Building Code stipulates that panel systems withstand the impact of a 9-pound, 2x4 timber traveling at 50 feet per second.

Safety/Class A Rating Per ASTM E84

	Flame Spread	Smoke Developed
Reynobond PE without Joint	PASS* CLASS A	PASS* CLASS A
Reynobond PE with Joint	PASS* CLASS A	PASS* CLASS A
Reynobond FR with Joint	PASS* CLASS A	PASS* CLASS A
Reynobond with KEVLAR®	PASS* CLASS A	PASS* CLASS A

*Flame spread ≤ 25, smoke developed ≤ 450.

Common Installation Methods

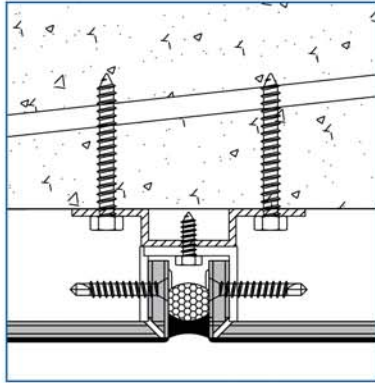

Wet-Seal System

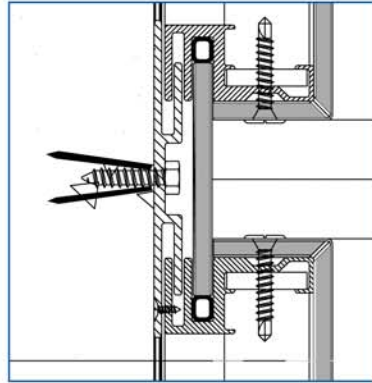

Dry-Seal Installation System

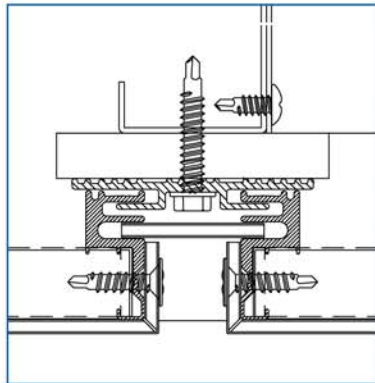

Rainscreen

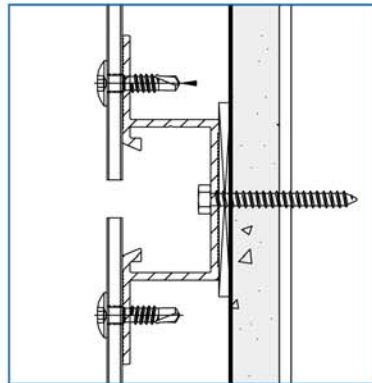

Face Fastened Solution

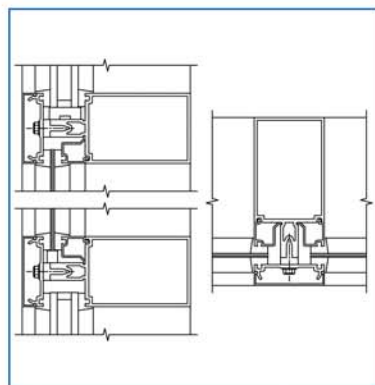

Curtain Wall Glazed-In Panel

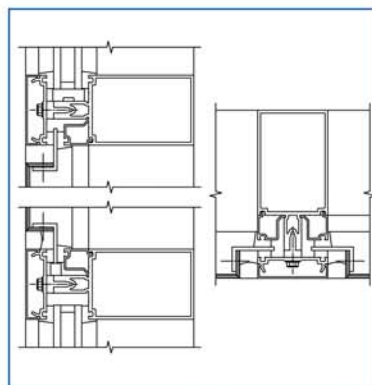

Curtain Wall Flush Panel

Alcoa Architectural Products

50 Industrial Boulevard
 Eastman, GA 31023-4129
 Tel. 800 841 7774
reynobond.com



©2012 Alcoa Architectural Products. Reynobond® is a registered trademark of Alcoa Inc. EcoClean™ is a trademark of Alcoa Inc. TOTO® is a registered trademark of TOTO LTD. HYDROTECT™ is a trademark of TOTO LTD. KEVLAR® is a registered trademark of E. I. du Pont de Nemours and Company and is used under license by Alcoa Architectural Products.

12AAP3407 November 2012 ver. 2.0 20000